

Aluminum Capacitors, Power High Ripple Current Snap-In

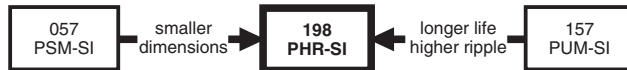

Fig. 1

QUICK REFERENCE DATA	
DESCRIPTION	VALUE
Nominal case size (Ø D x L in mm)	22 x 25 to 35 x 60
Rated capacitance range (E6/E12 series), C _R	56 µF to 680 µF
Tolerance on C _R	± 20 %
Rated voltage range, U _R	400 V and 450 V
Category temperature range	- 25 °C to + 85 °C
Endurance test at 85 °C	7000 h
Useful life at 85 °C	15 000 h
Shelf life at 0 V, 85 °C	1000 h
Based on sectional specification	IEC 60384-4/EN130300
Climatic category IEC 60068	25/085/56

FEATURES

- Polarized aluminum electrolytic capacitors, non-solid electrolyte
- Large types, miniaturized dimensions, cylindrical aluminum case, insulated with a blue sleeve
- Very high ripple current capability
- Keyed polarity version available
- High reliability
- Compliant to RoHS Directive 2002/95/EC

RoHS
COMPLIANT

APPLICATIONS

- Motor control and industrial systems
- Smoothing and filtering
- Standard and switched mode power supplies
- Energy storage in pulse systems

MARKING

The capacitors are marked (where possible) with the following information:

- Rated capacitance (in µF)
- Tolerance code on rated capacitance, code letter in accordance with IEC 60062 (M for ± 20 %)
- Rated voltage (in V)
- Date code (YYMM)
- Name of manufacturer
- Code for factory of origin
- “-” sign to identify the negative terminal, visible from the top and side of the capacitor
- Code number
- Climatic category in accordance with IEC 60068

SELECTION CHART FOR C _R , U _R , AND RELEVANT NOMINAL CASE SIZES (Ø D x L in mm)		
C _R (µF)	U _R (V)	
	400	450
56	22 x 25	22 x 25
68	22 x 25	22 x 30
82	-	22 x 30
	-	25 x 25
100	22 x 30	22 x 35
	-	25 x 30
120	22 x 35	22 x 40
	25 x 30	25 x 30
	-	30 x 25
150	22 x 40	25 x 40
	25 x 35	30 x 30
	25 x 40	25 x 40
180	30 x 30	30 x 35
	35 x 25	35 x 25
	25 x 45	25 x 50
220	30 x 35	30 x 40
	35 x 30	35 x 30

SELECTION CHART FOR C_R , U_R , AND RELEVANT NOMINAL CASE SIZES ($\varnothing D \times L$ in mm)		
C_R (μF)	U_R (V)	
	400	450
270	30 x 40	30 x 45
	35 x 30	35 x 35
330	30 x 45	30 x 50
	35 x 35	35 x 40
390	30 x 50	35 x 45
	35 x 40	-
470	35 x 45	35 x 50
560	35 x 50	35 x 60
680	35 x 60	35 x 60

DIMENSIONS in millimeters AND AVAILABLE FORMS

TWO TERMINAL SNAP-IN

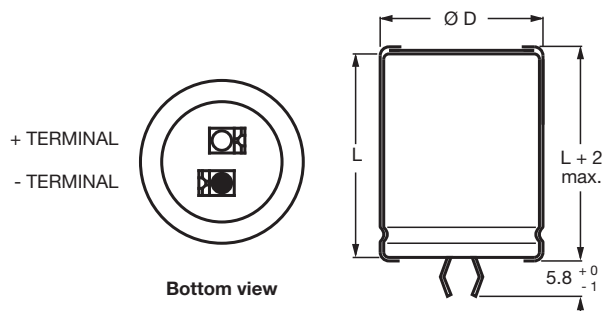

The minus terminal can be marked with a black dot or with an imprinted “-” sign.

Fig. 2 - Two terminal snap-in

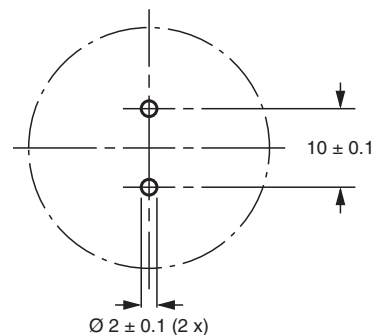
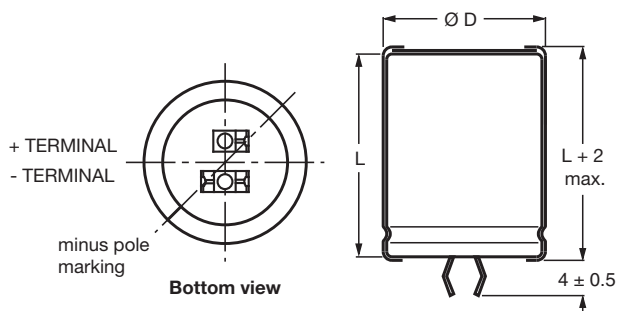

Fig. 3 - Mounting hole diagram

THREE TERMINAL SNAP-IN



The negative terminal has **TWO** pins which are **BOTH** electrically connected.

Fig. 4 - Three terminal snap-in

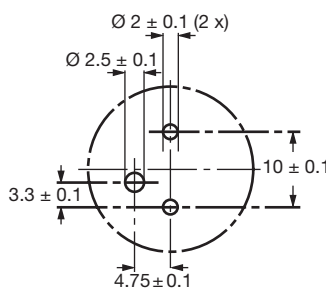

The 10 mm spacing of the 2 pin snap-in is used as the base layout and a third hole is added.

The third hole is closer to the negative primary hole so that polarization is always maintained, together with added mechanical stability.

Fig. 5 - Mounting hole diagram



Table 1

DIMENSIONS in millimeters, MASS AND PACKAGING QUANTITIES					
NOMINAL CASE SIZE Ø D x L	Ø D _{max.}	L _{max.}	MASS (g)	PACKAGING QUANTITIES (units per box)	CARDBOARD BOX DIMENSIONS L x W x H (mm)
22 x 25	23	27	≈ 12	100	260 x 250 x 39
22 x 30	23	32	≈ 16	100	260 x 250 x 44
22 x 35	23	37	≈ 20	100	260 x 250 x 49
22 x 40	23	42	≈ 23	100	260 x 250 x 54
25 x 25	26	27	≈ 20	100	290 x 280 x 39
25 x 30	26	32	≈ 22	100	290 x 280 x 44
25 x 35	26	37	≈ 24	100	290 x 280 x 49
25 x 40	26	42	≈ 27	100	290 x 280 x 54
25 x 45	26	47	≈ 32	100	290 x 280 x 59
25 x 50	26	52	≈ 38	100	290 x 280 x 64
30 x 25	31	27	≈ 25	100	340 x 330 x 39
30 x 30	31	32	≈ 30	100	340 x 330 x 44
30 x 35	31	37	≈ 35	100	340 x 330 x 49
30 x 40	31	42	≈ 40	100	340 x 330 x 54
30 x 45	31	47	≈ 45	100	340 x 330 x 59
30 x 50	31	52	≈ 50	100	340 x 330 x 64
35 x 25	36	27	≈ 33	50	390 x 198 x 39
35 x 30	36	32	≈ 40	50	390 x 198 x 44
35 x 35	36	37	≈ 48	50	390 x 198 x 49
35 x 40	36	42	≈ 55	50	390 x 198 x 54
35 x 45	36	47	≈ 63	50	390 x 198 x 59
35 x 50	36	52	≈ 72	50	390 x 198 x 64
35 x 60	36	62	≈ 87	50	390 x 198 x 74

ELECTRICAL DATA	
SYMBOL	DESCRIPTION
C _R	rated capacitance at 100 Hz
I _R	rated RMS ripple current at 100 Hz, 85 °C
I _{L1}	max. leakage current after 1 min at U _R
I _{L5}	max. leakage current after 5 min at U _R
ESR	typ./max. equivalent series resistance at 100 Hz
Z	typ./max. impedance at 10 kHz

Note

- Unless otherwise specified, all electrical values in table 2 apply at T_{amb} = 20 °C, P = 86 kPa to 106 kPa, RH = 45 % to 75 %

ORDERING EXAMPLE

Electrolytic capacitor 198 PHR-SI

470 µF/450 V; ± 20 %

Nominal case size: Ø 35 mm x 50 mm

2-terminal snap-in:

Ordering code: MAL2 198 57471 E3

Former 12NC: 2222 198 57471

3-terminal snap-in:

Ordering code: MAL2 198 77471 E3

Former 12NC: 2222 198 77471

Table 2

ELECTRICAL DATA AND ORDERING INFORMATION											
U _R (V)	C _R 100 Hz (μF)	NOMINAL CASE SIZE Ø D x L (mm)	I _R 100 Hz 85 °C (A)	I _{L1} 1 min (μA)	I _{L5} 5 min (μA)	TYP. ESR 100 Hz (mΩ)	MAX. ESR 100 Hz (mΩ)	TYP. Z 10 kHz (mΩ)	MAX. Z 10 kHz (mΩ)	ORDERING CODE MAL2198.....	
										2-TERM.	3-TERM.
400	56	22 x 25	0.72	138	49	918	1706	521	1085	56569E3	76569E3
	68	22 x 25	0.79	167	59	762	1405	434	905	56689E3	76689E3
	100	22 x 30	1.00	244	84	520	956	297	610	56101E3	76101E3
	120	22 x 35	1.14	292	100	433	796	247	450	46121E3	26121E3
	120	25 x 30	1.14	292	100	438	796	252	450	36121E3	16121E3
	150	22 x 40	1.33	364	124	348	637	199	363	66151E3	86151E3
	150	25 x 35	1.33	364	124	351	637	202	363	36151E3	16151E3
	180	25 x 40	1.51	436	148	293	531	169	295	36181E3	16181E3
	180	30 x 30	1.49	436	148	305	531	180	295	66181E3	86181E3
	180	35 x 25	1.56	436	148	327	531	200	295	26181E3	76181E3
	220	25 x 45	1.75	532	180	241	434	139	280	36221E3	90008E3
	220	30 x 35	1.56	532	180	250	434	147	280	26221E3	76221E3
	220	35 x 30	1.81	532	180	259	434	155	280	16221E3	86221E3
	270	30 x 40	1.95	652	220	205	354	121	263	36271E3	16271E3
	270	35 x 30	1.93	652	220	222	354	137	263	66271E3	86271E3
	330	30 x 45	2.22	796	268	169	290	101	210	36331E3	16331E3
	330	35 x 35	2.18	796	268	181	290	112	210	66331E3	86331E3
	390	30 x 50	2.50	940	316	145	245	86	175	36391E3	16391E3
	390	35 x 40	2.44	940	316	154	245	95	175	66391E3	86391E3
	470	35 x 45	2.72	1132	380	129	203	80	153	36471E3	16471E3
560	35 x 50	3.03	1348	452	110	171	70	133	46561E3	26561E3	
680	35 x 60	3.53	1636	548	91	140	57	110	46681E3	26681E3	
450	56	22 x 25	0.71	155	54.4	865	1706	561	1100	57569E3	77569E3
	68	22 x 30	0.82	188	65.2	709	1405	564	1100	57689E3	77689E3
	82	22 x 30	0.89	225	77.8	592	1165	459	900	47829E3	27829E3
	82	25 x 25	0.91	225	77.8	604	1165	473	900	57829E3	77829E3
	100	22 x 35	1.02	274	94	485	956	360	700	47101E3	27101E3
	100	25 x 30	1.05	274	94	491	956	365	700	57101E3	77101E3
	120	22 x 40	1.14	328	112	406	796	305	600	47121E3	27121E3
	120	25 x 30	1.13	328	112	415	796	316	600	57121E3	77121E3
	120	30 x 25	1.16	328	112	431	796	336	600	67121E3	87121E3
	150	25 x 40	1.36	409	139	328	637	261	500	47151E3	27151E3
	150	30 x 30	1.36	409	139	340	637	275	500	57151E3	77151E3
	180	25 x 40	1.47	490	166	277	531	207	400	47181E3	27181E3
	180	30 x 35	1.54	490	166	282	531	213	400	57181E3	77181E3
	180	35 x 25	1.46	490	166	316	531	252	400	67181E3	87181E3
	220	25 x 50	1.71	598	202	226	434	127	263	47221E3	27221E3
	220	30 x 40	1.75	598	202	232	434	177	350	57221E3	77221E3
	220	35 x 30	1.72	598	202	248	434	197	350	67221E3	87221E3
	270	30 x 45	1.98	733	247	191	354	147	300	47271E3	27271E3
	270	35 x 35	1.96	733	247	202	354	160	300	57271E3	77271E3
	330	30 x 50	2.22	895	301	158	290	117	250	47331E3	27331E3
330	35 x 40	2.22	895	301	167	290	128	250	57331E3	77331E3	
390	35 x 45	2.46	1057	355	142	245	100	200	57391E3	77391E3	
470	35 x 50	2.73	1273	427	120	203	88	175	57471E3	77471E3	
560	35 x 60	3.10	1516	508	100	171	75	150	57561E3	77561E3	
680	35 x 60	3.30	1840	616	88	140	70	140	57681E3	77681E3	

CUSTOMIZED PRODUCTS

If you are unable to find the capacitor you require, please contact your local Vishay BCcomponents sales organization; we are able to design and manufacture customized capacitors to meet your specific requirements.



ADDITIONAL ELECTRICAL DATA		
PARAMETER	CONDITIONS	VALUE
Voltage		
Surge voltage	≥ 400 V versions	$U_s = 1.1 \times U_R$
Reverse voltage		≤ 1 V
Current		
Leakage current	after 1 min at U_R	$I_{L1} \leq 0.006 C_R \times U_R + 4 \mu A$
	after 5 min at U_R	$I_{L5} \leq 0.002 C_R \times U_R + 4 \mu A$
Inductance		
Equivalent series inductance (ESL)	all case sizes	typ. 19 nH
		max. 25 nH

RIPPLE CURRENT AND USEFUL LIFE

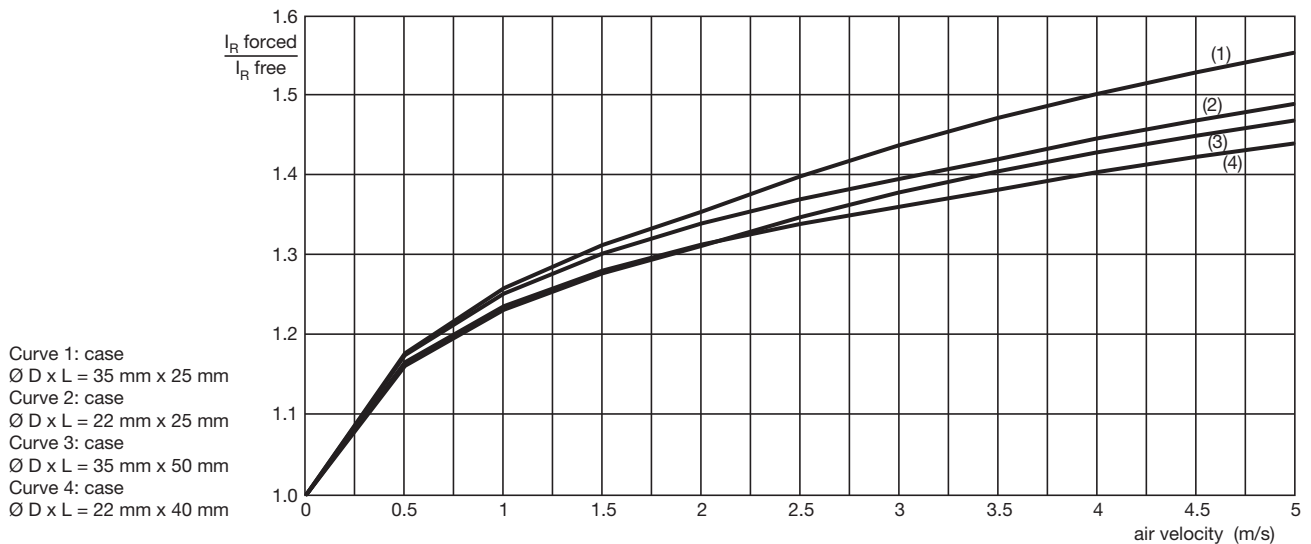

Fig. 6 - Multiplier of ripple current (I_R) as a function of air-flow

MAXIMUM RIPPLE CURRENT MULTIPLIER			
PARAMETER	CONDITION	MAXIMUM RIPPLE CURRENT MULTIPLIER	VALUE
Ambient temperature (T_{amb})	70 °C	from nomogram; see Fig. 7	1.57
Operating frequency (f)	300 Hz	from frequency table; see Table 3	1.17
Air-flow	2 m/s	from air-flow; see Fig. 6	1.35

Note

- Calculation example for case Ø D x L = 35 mm x 25 mm.
Therefore the maximum ripple current multiplier at 70 °C, 300 Hz and 2 m/s air-flow = 1.57 x 1.17 x 1.35 = 2.48.

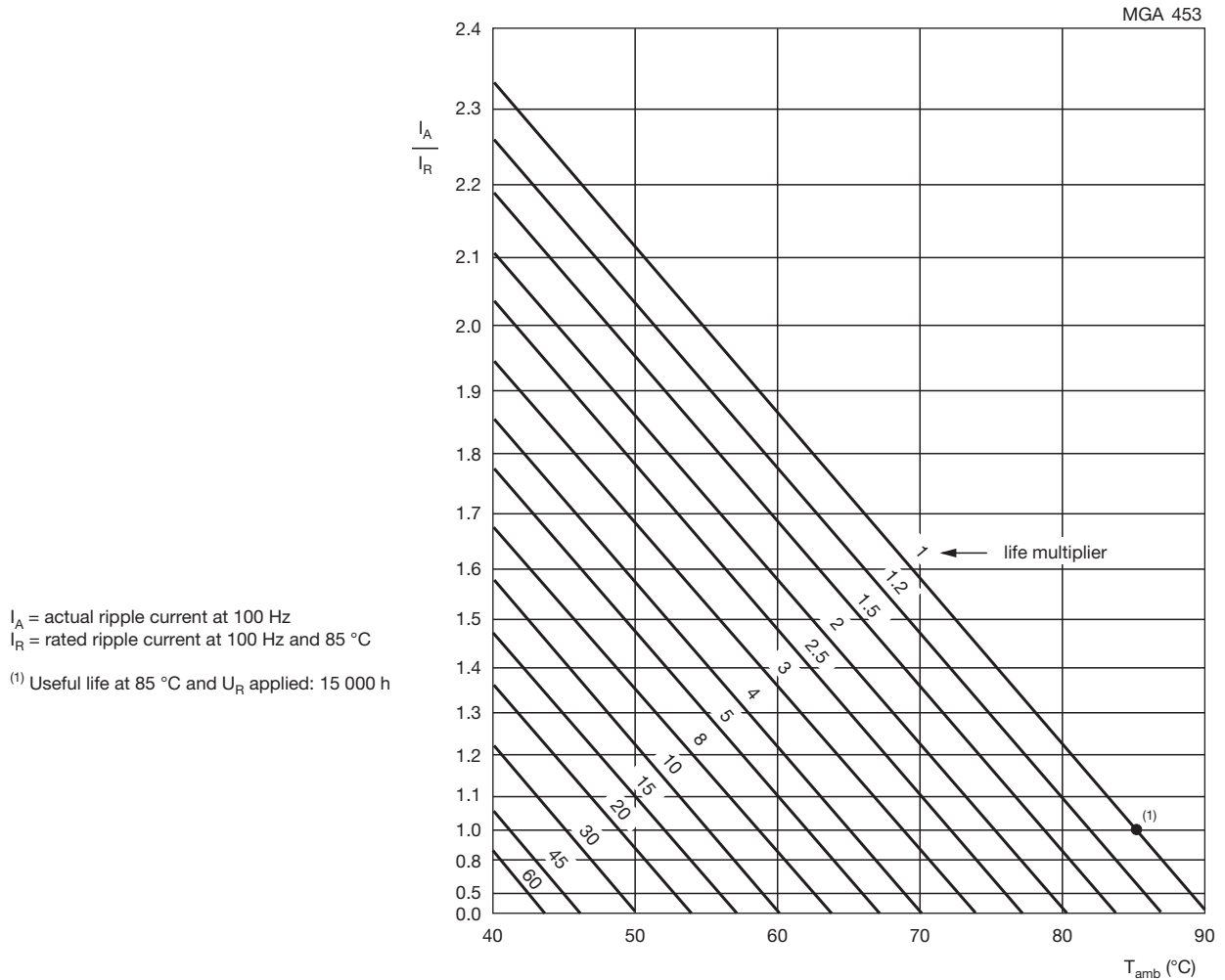

Fig. 7 - Multiplier of useful life as a function of ambient temperature and ripple current load

Table 3

MULTIPLIER OF RIPPLE CURRENT (I_R) AS A FUNCTION OF FREQUENCY	
FREQUENCY (Hz)	I_R MULTIPLIER
50	0.86
100	1.00
300	1.17
600	1.24
1000	1.29
≥ 10 000	1.40



Table 4

TEST PROCEDURES AND REQUIREMENTS			
TEST		PROCEDURE (quick reference)	REQUIREMENTS
NAME OF TEST	REFERENCE		
Endurance	IEC 60384-4/ EN130300 subclause 4.13	$T_{amb} = 85\text{ }^{\circ}\text{C}$; U_R applied; 7000 h	$\Delta C/C: \pm 10\%$ $ESR \leq 2 \times \text{spec. limit}$ $I_{L5} \leq \text{spec. limit}$
Useful life	CECC 30301 subclause 1.8.1	$T_{amb} = 85\text{ }^{\circ}\text{C}$; U_R and I_R applied; 15 000 h	$\Delta C/C: \pm 30\%$ $ESR \leq 3 \times \text{spec. limit}$ $I_{L5} \leq \text{spec. limit}$
Shelf life (storage at high temperature)	IEC 60384-4/ EN130300 subclause 4.17	$T_{amb} = 85\text{ }^{\circ}\text{C}$; no voltage applied; 1000 h after test: U_R to be applied for 30 min, 24 h to 48 h before measurement	$\Delta C/C: \pm 15\%$ $ESR \leq 2 \times \text{spec. limit}$ $I_{L5} \leq 2 \times \text{spec. limit}$



Disclaimer

ALL PRODUCT, PRODUCT SPECIFICATIONS AND DATA ARE SUBJECT TO CHANGE WITHOUT NOTICE TO IMPROVE RELIABILITY, FUNCTION OR DESIGN OR OTHERWISE.

Vishay Intertechnology, Inc., its affiliates, agents, and employees, and all persons acting on its or their behalf (collectively, "Vishay"), disclaim any and all liability for any errors, inaccuracies or incompleteness contained in any datasheet or in any other disclosure relating to any product.

Vishay makes no warranty, representation or guarantee regarding the suitability of the products for any particular purpose or the continuing production of any product. To the maximum extent permitted by applicable law, Vishay disclaims (i) any and all liability arising out of the application or use of any product, (ii) any and all liability, including without limitation special, consequential or incidental damages, and (iii) any and all implied warranties, including warranties of fitness for particular purpose, non-infringement and merchantability.

Statements regarding the suitability of products for certain types of applications are based on Vishay's knowledge of typical requirements that are often placed on Vishay products in generic applications. Such statements are not binding statements about the suitability of products for a particular application. It is the customer's responsibility to validate that a particular product with the properties described in the product specification is suitable for use in a particular application. Parameters provided in datasheets and/or specifications may vary in different applications and performance may vary over time. All operating parameters, including typical parameters, must be validated for each customer application by the customer's technical experts. Product specifications do not expand or otherwise modify Vishay's terms and conditions of purchase, including but not limited to the warranty expressed therein.

Except as expressly indicated in writing, Vishay products are not designed for use in medical, life-saving, or life-sustaining applications or for any other application in which the failure of the Vishay product could result in personal injury or death. Customers using or selling Vishay products not expressly indicated for use in such applications do so at their own risk and agree to fully indemnify and hold Vishay and its distributors harmless from and against any and all claims, liabilities, expenses and damages arising or resulting in connection with such use or sale, including attorneys fees, even if such claim alleges that Vishay or its distributor was negligent regarding the design or manufacture of the part. Please contact authorized Vishay personnel to obtain written terms and conditions regarding products designed for such applications.

No license, express or implied, by estoppel or otherwise, to any intellectual property rights is granted by this document or by any conduct of Vishay. Product names and markings noted herein may be trademarks of their respective owners.