

# Surface Mount Aluminum Electrolytic Capacitors NACEW Series

## FEATURES

- CYLINDRICAL V-CHIP CONSTRUCTION
- WIDE TEMPERATURE -55 ~ +105°C
- DESIGNED FOR REFLOW SOLDERING

**RoHS Compliant**  
includes all homogeneous materials



\*See Part Number System for Details

## CHARACTERISTICS

Rated Voltage Range	6.3 ~ 100Vdc**									
Rate Capacitance Range	1.0 ~ 6,800µF									
Operating Temp. Range	-55°C ~ +105°C (100V -40°C ~ +105 °C)									
Capacitance Tolerance	±20% (M)									
Max. Leakage Current After 2 Minutes @ 20°C	0.01CV or 3µA whichever is greater									
Max. Tan δ @ 120Hz/20°C	W.V. (Vdc)	6.3	10	16	25	35	50	63	100	
	S.V. (Vdc)	8	13	20	32	44	63	79	125	
	4 ~ 6.3mm Dia.	0.24	0.20	0.16	0.14	0.12	0.10	0.12	0.10	
	8 & larger	0.28	0.24	0.20	0.16	0.14	0.12	0.12	0.10	
Low Temperature Stability Impedance Ratio @ 120Hz	W.V. (Vdc)	6.3	10	16	25	35	50	63	100	
	Z-40°C/Z+20°C	3	3	2	2	2	2	2	2	
	Z-55°C/Z+20°C	8	6	4	4	3	3	3	-	
Load Life Test	4 ~ 6.3mm Dia. & 10x8mm +105°C 1,000 hours	Capacitance Change		Within ± 25% of initial measured value						
		Tan δ		Less than 200% of specified max. value						
	8 ~ 16mm Dia. +105°C 2,000 hours	Leakage Current		Less than specified max. value						

\*\* For higher voltages, 200V and 400V, see NACV series.

## STANDARD PRODUCT AND CASE SIZE TABLE DφxL (mm)

Cap. (µF)	Code	Working Voltage (Vdc)							
		6.3	10	16	25	35	50	63	100
1.0	1R0	-	-	-	-	-	4x5.5	4x5.5	4x6.3
2.2	2R2	-	-	-	-	-	4x5.5	4x5.5	6.3x6.3
3.3	3R3	-	-	-	-	-	4x5.5	5x5.5	6.3x6.3
4.7	4R7	-	-	-	4x5.5	4x5.5	5x5.5	5x5.5	6.3x6.3
10	100	-	-	4x5.5	5x5.5	5x5.5	6.3x5.5	6.3x5.5	6.3x8
22	220	4x5.5	5x5.5	5x5.5	6.3x5.5	6.3x5.5	6.3x6.3	6.3x8	8x10.5
33	330	5x5.5	5x5.5	6.3x5.5	6.3x5.5	6.3x6.3	6.3x8	8x10.5	10x10.5
47	470	5x5.5	6.3x5.5	6.3x5.5	6.3x6.3	6.3x6.3	6.3x8	8x10.5	12.5x14
100	101	6.3x5.5	-	6.3x5.5	6.3x8	6.3x8	8x10.5	10x10.5	-
150	151	6.3x5.5	6.3x6.3	6.3x8	8x10.5	8x10.5 10x8	-	-	16x17
220	221	6.3x6.3	6.3x8	6.3x8	8x10.5 10x8*	8x10.5	10x10.5	12.5x14	-
330	331	6.3x8	8x10.5	8x10.5 10x8	8x10.5	10x10.5	-	-	-
470	471	8x10.5	8x10.5 10x8	8x10.5	10x10.5	12.5x14	-	16x17	-
1000	102	8x10.5	10x10.5	-	12.5x14	-	16x17	-	-
1500	152	10x10.5	-	12.5x14	-	16x17	-	-	-
2200	222	-	12.5x14	-	16x17	-	-	-	-
3300	332	12.5x14	-	16x17	-	-	-	-	-
4700	472	-	16x17	-	-	-	-	-	-
6800	682	16x17	-	-	-	-	-	-	-

## PRECAUTIONS

Please review the notes on correct use, safety and precautions found on pages T10 & T11 of NIC's Electrolytic Capacitor catalog.  
Also found at [www.nicomp.com/precautions](http://www.nicomp.com/precautions)  
If in doubt or uncertainty, please review your specific application - process details with NIC's technical support personnel: [tpmg@nicomp.com](mailto:tpmg@nicomp.com)



# Surface Mount Aluminum Electrolytic Capacitors NACEW Series

## STANDARD VALUES, CASE SIZES AND SPECIFICATIONS

NIC Part Number	Cap. (μF)	W.V. (Vdc)	Dissipation Factor (Tan δ)	Max. Ripple Current (mA) +105°C/120Hz	Maximum ESR (Ω) +20°C/120Hz	Load Life Hours @ +105°C	
NACEW220M6.3V4X5.5TR13F	22	6.3	0.24	22	18.1	1,000	
NACEW330M6.3V5X5.5TR13F	33		0.24	27	12.1	1,000	
NACEW470M6.3V5X5.5TR13F	47		0.24	33	8.47	1,000	
NACEW101M6.3V6.3X5.5TR13F	100		0.24	50	3.98	1,000	
NACEW151M6.3V6.3X5.5TR13F	150		0.24	55	2.66	1,000	
NACEW221M6.3V6.3X6.3TR13F	220		0.24	67	1.81	1,000	
NACEW331M6.3V6.3X8TR13F	330		0.24	105	1.21	1,000	
NACEW471M6.3V8X10.5TR13F	470		0.28	210	0.99	2,000	
NACEW102M6.3V8X10.5TR13F	1000		0.28	280	0.46	2,000	
NACEW152M6.3V10X10.5TR13F	1500		0.28	310	0.31	2,000	
NACEW332M6.3V12.5X14TR15F	3300		0.28	520	0.14	2,000	
NACEW682M6.3V16X17TR15F	6800		0.28	930	0.093	2,000	
NACEW220M10V5X5.5TR13F	22		10	0.20	25	15.1	1,000
NACEW330M10V5X5.5TR13F	33	0.20		30	10.1	1,000	
NACEW470M10V5X5.5TR13F	47	0.20		41	7.06	1,000	
NACEW151M10V6.3X6.3TR13F	150	0.20		62	2.21	1,000	
NACEW221M10V6.3X8TR13F	220	0.20		105	1.51	1,000	
NACEW331M10V8X10.5TR13F	330	0.24		195	1.21	2,000	
NACEW471M10V8X10.5TR13F	470	0.24		210	0.85	2,000	
NACEW471M10V10X8TR13F	470	0.24		210	0.85	1,000	
NACEW102M10V10X10.5TR13F	1000	0.24		310	0.40	2,000	
NACEW222M10V12.5X14TR15F	2200	0.24		510	0.18	2,000	
NACEW472M10V16X17TR15F	4700	0.24		880	0.11	2,000	
NACEW100M16V4X5.5TR13F	10	16		0.16	18	26.5	1,000
NACEW220M16V5X5.5TR13F	22			0.16	27	12.1	1,000
NACEW330M16V6.3X5.5TR13F	33		0.16	40	8.04	1,000	
NACEW470M16V6.3X5.5TR13F	47		0.16	48	5.65	1,000	
NACEW101M16V6.3X5.5TR13F	100		0.16	60	2.66	1,000	
NACEW151M16V6.3X8TR13F	150		0.16	95	1.77	1,000	
NACEW221M16V6.3X8TR13F	220		0.16	105	1.21	1,000	
NACEW331M16V8X10.5TR13F	330		0.20	195	1.00	2,000	
NACEW331M16V10X8TR13F	330		0.20	195	1.00	1,000	
NACEW471M16V8X10.5TR13F	470		0.20	230	0.71	2,000	
NACEW152M16V12.5X14TR15F	1500		0.20	500	0.23	2,000	
NACEW332M16V16X17TR15F	3300		0.20	840	0.12	2,000	
NACEW4R7M25V4X5.5TR13F	4.7		25	0.14	13	49.4	1,000
NACEW100M25V5X5.5TR13F	10	0.14		20	23.2	1,000	
NACEW220M25V6.3X5.5TR13F	22	0.14		36	10.6	1,000	
NACEW330M25V6.3X5.5TR13F	33	0.14		44	7.04	1,000	
NACEW470M25V6.3X6.3TR13F	47	0.14		48	4.95	1,000	
NACEW101M25V6.3X8TR13F	100	0.14		91	2.32	1,000	
NACEW151M25V8X10.5TR13F	150	0.16		140	1.77	2,000	
NACEW221M25V8X10.5TR13F	220	0.16		175	1.21	2,000	
NACEW221M25V10X8TR13F	220	0.16		175	1.21	1,000	
NACEW331M25V8X10.5TR13F	330	0.16		220	0.80	2,000	
NACEW471M25V10X10.5TR13F	470	0.16		300	0.57	2,000	
NACEW102M25V12.5X14TR15F	1000	0.16		460	0.27	2,000	
NACEW222M25V16X17TR15F	2200	0.16		805	0.14	2,000	
NACEW4R7M35V4X5.5TR13F	4.7	35	0.12	14	42.3	1,000	
NACEW100M35V5X5.5TR13F	10		0.12	21	19.9	1,000	
NACEW220M35V6.3X5.5TR13F	22		0.12	38	9.05	1,000	
NACEW330M35V6.3X6.3TR13F	33		0.12	42	6.04	1,000	
NACEW470M35V6.3X6.3TR13F	47		0.12	49	4.24	1,000	
NACEW101M35V6.3X8TR13F	100		0.12	84	2.32	1,000	
NACEW151M35V8X10.5TR13F	150		0.14	155	1.55	2,000	
NACEW151M35V10X8TR13F	150		0.14	155	1.55	1,000	
NACEW221M35V8X10.5TR13F	220		0.14	190	1.06	2,000	
NACEW331M35V10X10.5TR13F	330		0.14	300	0.70	2,000	
NACEW471M35V12.5X14TR15F	470		0.14	410	0.49	2,000	
NACEW152M35V16X17TR15F	1500		0.14	740	0.15	2,000	

For Automotive Equipment see part number system



# Surface Mount Aluminum Electrolytic Capacitors NACEW Series

## STANDARD VALUES, CASE SIZES AND SPECIFICATIONS

NIC Part Number	Cap. (μF)	W.V. (Vdc)	Dissipation Factor (Tan δ)	Max. Ripple Current (mA) +105°C/120Hz	Maximum ESR (Ω) +20°C/120Hz	Load Life Hours @ +105°C
NACEW1R0M50V4X5.5TR13F	1.0	50	0.10	7.0	166	1,000
NACEW2R2M50V4X5.5TR13F	2.2		0.10	11	75.4	1,000
NACEW3R3M50V4X5.5TR13F	3.3		0.10	13	50.3	1,000
NACEW4R7M50V5X5.5TR13F	4.7		0.10	16	35.3	1,000
NACEW100M50V6.3X5.5TR13F	10		0.10	24	16.6	1,000
NACEW220M50V6.3X6.3TR13F	22		0.10	32	7.64	1,000
NACEW330M50V6.3x8TR13F	33		0.10	60	5.03	1,000
NACEW470M50V6.3x8TR13F	47		0.10	63	3.53	1,000
NACEW101M50V8x10.5TR13F	100		0.12	140	1.99	2,000
NACEW221M50V10X10.5TR13F	220		0.12	220	0.91	2,000
NACEW102M50V16X17TR15F	1000		0.12	655	0.20	2,000
NACEW1R0M63V4X5.5TR13F	1.0	63	0.12	7.0	199	1,000
NACEW2R2M63V4X5.5TR13F	2.2		0.12	11	90.5	1,000
NACEW3R3M63V4X5.5TR13F	3.3		0.12	14	60.3	1,000
NACEW4R7M63V5X5.5TR13F	4.7		0.12	16	42.3	1,000
NACEW100M63V6.3X5.5TR13F	10		0.12	24	19.9	1,000
NACEW220M63V6.3X8TR13F	22		0.12	49	9.04	1,000
NACEW330M63V8X10.5TR13F	33		0.12	112	6.03	1,000
NACEW470M63V8X10.5TR13F	47		0.12	119	4.24	1,000
NACEW101M63V10X10.5TR13F	100		0.12	196	1.99	2,000
NACEW221M63V12.5X14TR15F	220		0.12	287	0.91	2,000
NACEW471M63V16X17TR15F	470		0.12	630	0.42	2,000
NACEW1R0M100V4X6.3TR13F	1.0	100V	0.10	7.0	166	1,000
NACEW2R2M100V6.3X6.3TR13F	2.2		0.10	14	75.4	1,000
NACEW3R3M100V6.3X6.3TR13F	3.3		0.10	20	50.3	1,000
NACEW4R7M100V6.3X6.3TR13F	4.7		0.10	25	35.3	1,000
NACEW100M100V6.3X8TR13F	10		0.10	35	16.6	1,000
NACEW220M100V8X10.5TR13F	22		0.10	84	7.64	2,000
NACEW330M100V10x10.5TR13F	33		0.10	133	5.03	2,000
NACEW470M100V12.5X14TR15F	47		0.10	240	3.53	2,000
NACEW151M100V16X17TR15F	150		0.10	500	1.10	2,000

For Automotive Equipment see part number system

### PART NUMBER SYSTEM

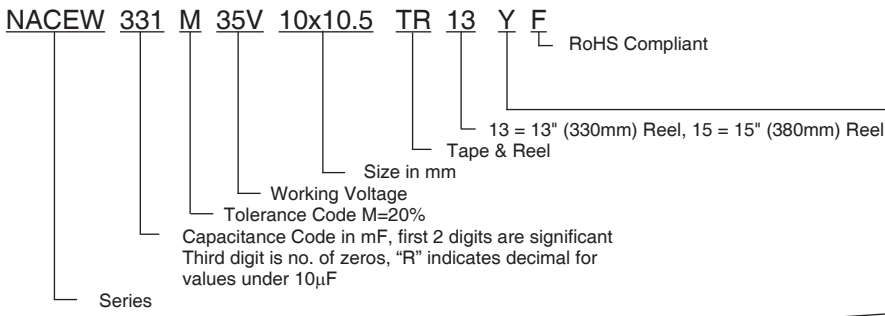

Optional: Suitable for automotive equipment, sourced to special production and inspection at TS-16949 certified production site

Case Diameter	Termination Material
4 ~ 10mm φ	97% Sn, 3% Bi
12.5mm	99.3% Sn, 0.7% Bi
16mm	100% Sn



# Surface Mount Aluminum Electrolytic Capacitors NACEW Series

## RIPPLE CURRENT FREQUENCY CORRECTION FACTOR

Frequency (Hz)	$f \leq 100$	$100 > f \leq 1K$	$1K > f \leq 10K$	$f \geq 100K$
Correction Factor	0.8	1.0	1.3	1.5

## DIMENSIONS (mm)

Case Size	$D\phi \pm 0.5$	L max.	$A \pm 0.2$	$B \pm 0.2$	$I \pm 0.2$	W	$P \pm 0.2$
4 x 5.5	4.0	5.5	4.3	4.3	1.8	0.5 ~ 0.8	1.0
5 x 5.5	5.0	5.5	5.3	5.3	2.1	0.5 ~ 0.8	1.4
6.3 x 5.5	6.3	5.5	6.6	6.6	2.5	0.5 ~ 0.8	2.2
6.3 x 6.3	6.3	6.3	6.6	6.6	2.5	0.5 ~ 0.8	2.2
6.3 x 8	6.3	8.0	6.6	6.6	2.5	0.5 ~ 0.8	2.2
8 x 6.5	8.0	6.5	8.3	8.3	3.4	0.5 ~ 0.8	2.2
8 X 10.5	8.0	10.5	8.3	8.3	2.9	0.7 ~ 1.0	3.2
10 x 8	10.0	8.0	10.3	10.3	3.2	0.7 ~ 1.4	4.6
10 x 10.5	10.0	10.5	10.3	10.3	3.2	0.7 ~ 1.4	4.6
12.5 x 14	12.5	14.0	12.8	12.8	4.5	0.6 ~ 1.4	4.6
16 x 17	16.0	17.5	17.0	17.0	5.5	0.9 ~ 1.5	6.7

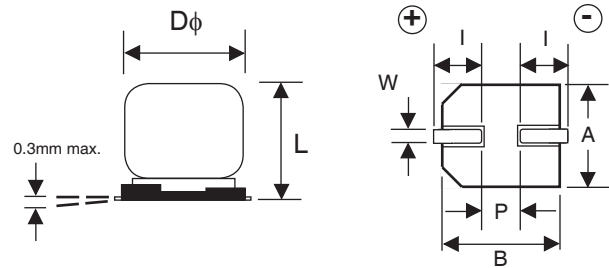

## PEAK REFLOW TEMPERATURE AND DURATION

Diameter	Time above 200°C	Peak Temperature 5 seconds
4x5.5	70 sec.	250°C
4x6.3	60 sec.	250°C
5x5.5	70 sec.	250°C
6.3x5.5 (<63V)	70 sec.	250°C
6.3x5.5 (100V)	60 sec.	250°C
6.3x6.3 (<63V)	70 sec.	250°C
6.3x6.3 (100V)	60 sec.	250°C
6.3x8 (<63V)	70 sec.	250°C
6.3x8 (100V)	60 sec.	250°C
8x10.5 (<63V)	60 sec.	245°C
8x10.5 (100V)	60 sec.	240°C
10x10.5 (<63V)	50 sec.	240°C
10x10.5 (100V)	50 sec.	235°C
12.5x14 (<63V)	50 sec.	240°C
12.5x14 (100V)	50 sec.	235°C
12.5x14 (<63V)	30 sec.	230°C
12.5x14 (100V)	30 sec.	230°C

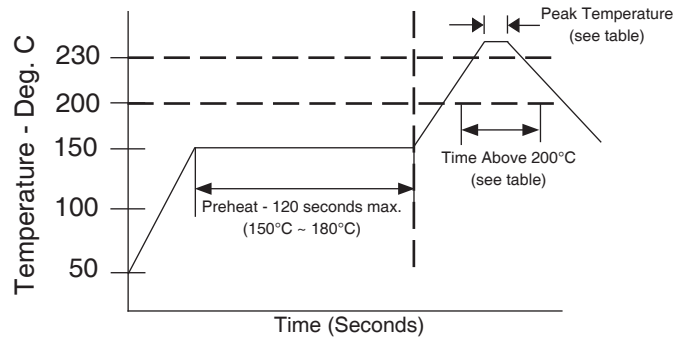

## RECOMMENDED LAND PATTERN DIMENSIONS (mm)

Case Size	a	b	c
4x5.5	1.0	2.6	1.8
4x6.3			
5x5.5	1.4	3.0	1.8
6.3x5.5	2.1	3.5	1.8
6.3x6.3			
6.3x8	3.0	4.1	2.2
8x10.5			
10x10.5	4.3	4.4	2.5
12.5x14	4.2	5.8	2.5
16x17	6.0	6.5	4.0

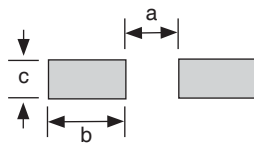

Review & Compare Reflow Soldering Heat Limits  
V-chip SMT Aluminum Electrolytic Capacitors  
[www.niccomp.com/RSL](http://www.niccomp.com/RSL)



# Surface Mount Aluminum Electrolytic Capacitors NACEW Series

## CARRIER TAPE

Case Size	A ±0.5	B ±0.2	C ±0.3	D ±0.1	P ±0.1	T ±0.2
4 x 5.5	4.7	4.7	12.0	5.5	8.0	5.8
5 x 5.5	5.7	5.7	12.0	5.5	12.0	5.8
6.3 x 5.5	7.0	7.0	16.0	7.5	12.0	5.8
6.3 x 6.3	7.0	7.0	16.0	7.5	12.0	6.6
6.3 x 8	7.0	7.0	16.0	7.5	12.0	8.3
8 x 6.5	8.7	8.7	16.0	7.5	12.0	6.8
8 X 10.5	8.7	8.7	24.0	11.5	16.0	11.1
10 x 8	10.7	10.7	24.0	11.5	16.0	8.3
10 x 10.5	10.7	10.7	24.0	11.5	16.0	11.2
12.5 x 14	13.2	13.2	32.0	14.2	24.0	14.2
16 x 17	17.5	17.5	44.0	20.2	28.0	17.5

## TR13 330mm (13") REEL TR15 380mm (15") REEL

Case Size	W ±1.0	Quantity Per Reel	
		13" Reel	15" Reel
4 x 5.5	14.0	1,500 pcs	2,000 pcs
5 x 5.5	14.0	1,000 pcs	1,000 pcs
6.3 x 5.5	18.0	1,000 pcs	1,000 pcs
6.3 x 6.3	18.0	800 pcs	1,000 pcs
6.3 x 8	18.0	500 pcs	900 pcs
8 x 6.5	18.0	800 pcs	1,000 pcs
8 X 10.5	26.0	300 pcs	500 pcs
10 x 8	26.0	400 pcs	500 pcs
10 x 10.5	26.0	300 pcs	500 pcs
12.5 x 14	34.0	N/A	250 pcs
16 x 17	46.0	N/A	200 pcs

## TAPING SPECIFICATIONS (mm)

1. Both Leader and Trailer tape: Minimum 40mm (1.57") empty carrier tape pockets.
2. Leader tape: Approximately 20cm of cover tape at leader.
3. Connection: Maximum 3 connections (slices) per reel.

### CARRIER

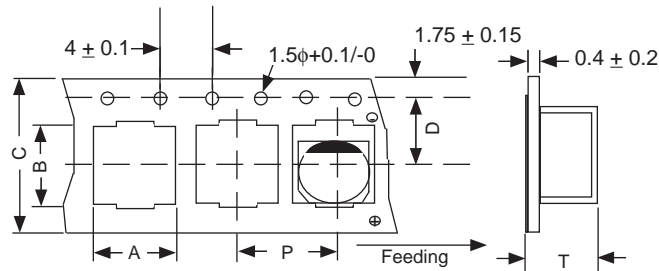

### REEL

