

Axial Multilayer Ceramic Capacitors

NCMA Series

FEATURES

- CONFORMALLY COATED, MINIATURE SIZE
- 50, 100, AND 200 Vdc
- NPO, X7R, AND Z5U TEMPERATURE COEFFICIENTS
- SUPPLIED ON TAPE AND REEL



PART NUMBER SYSTEM

*See Part Number System for Details

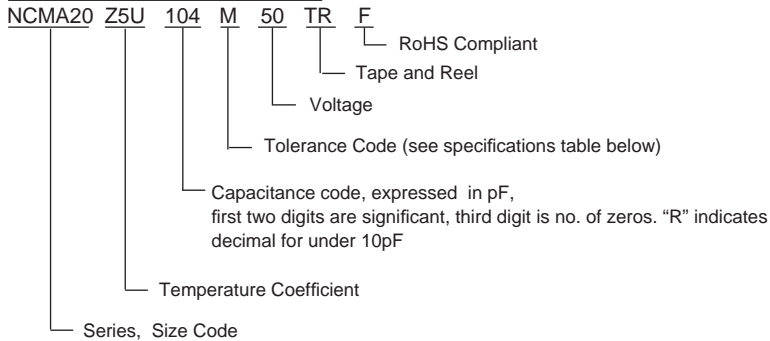

SPECIFICATIONS

Characteristics	NPO	X7R	Z5U
Capacitance Range*	1pF ~ 0.01µF	220pF ~ 0.47µF	0.01µF ~ 1.0µF
Capacitance Tolerance (Code)	±1%(F), ±2%(G), ±5%(J)	±5%(J), ±10%(K), ±20%(M)	±20%(M), +80%/-20%(Z)
Operating Temperature Range	-55°C to +125°C	-55°C to +125°C	+10°C to +85°C
Temperature Characteristics	0±30ppm/°C	±15% (0 Vdc)	+22%/-56%
Voltage Rating	50, 100 & 200 Vdc	50, 100 & 200 Vdc	50 & 100 Vdc
Dissipation Factor	0.15% Max. (+25°C and +125°C) for values greater than 30 pF. For values of 30pF and below: Q = 20 x C +400 1.0Vrms 1MHz for values ≤ 1000pF 1KHz for values > 1000pF	2.5% Max. at 1KHz, 1Vrms Max.	4.0% Max. at 1KHz, 5Vrms Max.
Insulation Resistance 25°C (Mil- STD-202, Method 302)	100K Megohms or 1000 Megohm -µF Min., Whichever is Less	100K Megohms or 1000 Megohm -µF Min., Whichever is Less	10K Megohms or 100 Megohm -µF Min., Whichever is Less
Dielectric Strength	250% of Rated Voltage	250% of Rated Voltage	200% of Rated Voltage
Life Test (1000 hours)	200% of Rated Voltage at +125°C	200% of Rated Voltage at +125°C	150% of Rated Voltage at +85°C

SIZE CODE AND AVAILABLE CAPACITANCE RANGE

Size Code	WVDC	NPO	X7R	Z5U
NCMA10	50	1000pF~1200pF	8200pF~0.047µF	0.068µF~0.22µF
	100	150pF~820pF	560pF~0.015µF	0.01µF~0.047µF
	200	1pF~330pF*	220pF~0.01µF	-
NCMA11	50	1800pF~3900pF	0.047µF~0.1µF	0.22µF~0.047µF
	100	1000pF~2700pF	0.018µF~0.039µF	0.1µF
NCMA20	50	1800pF~3900pF	0.027µF~0.1µF	0.047µF~0.1µF
	100	1000pF~1800pF	8200pF~0.033µF	0.033µF~0.047µF
NCMA30	50	4700pF~5600pF	0.056µF~0.33µF	0.15µF~1.0µF
	100	1800pF~3900pF	0.022µF~0.1µF	0.068µF~0.33µF
NCMA40	50	8200pF~0.01µF	0.33µF~0.47µF	-
	100	4700pF~8200pF	0.12µF~0.18µF	0.15µF~0.47µF

*-Selected values, Please contact NIC for availability.



Conformally Coated, Axial Multilayer Ceramic Capacitors

DIMENSIONS (mm)

Type	D Diameter	L Length
NCMA10	2.54	4.32
NCMA11	3.50	4.32
NCMA20	2.54	6.80
NCMA30	3.81	7.37
NCMA40	3.81	10.16

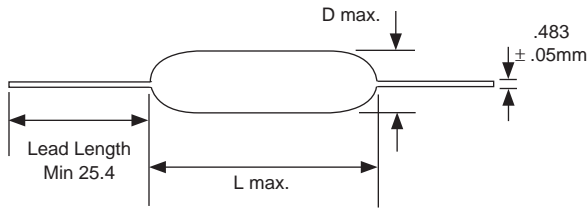

TAPE AND REEL CLASS 1 RS-296

A	5mm ± 0.5mm
B*	52.4mm ± 1.5mm
C	6.35mm ± 0.4mm
E	1.2mm
F	1.6mm
G	356mm
H	76mm
I	25.4mm
J	84mm
K	70mm

*ALSO AVAILABLE IN 26.0mm $+1.5mm$ $-0mm$

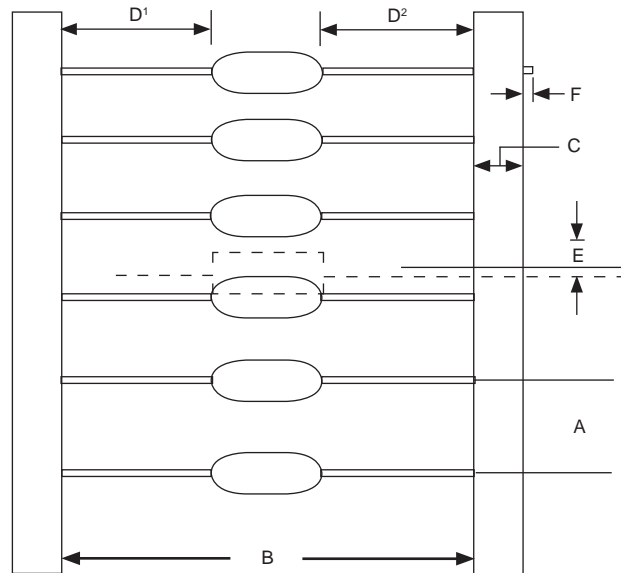

LEADER TAPE: 300mm min.
SPLICING TAPE: Tape Only
MISSING PARTS: 0.25% of component count max.
 No consecutive missing parts

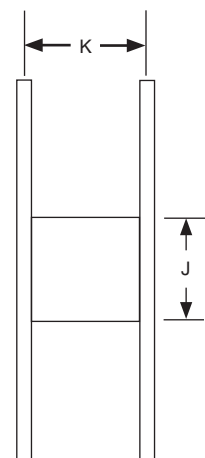
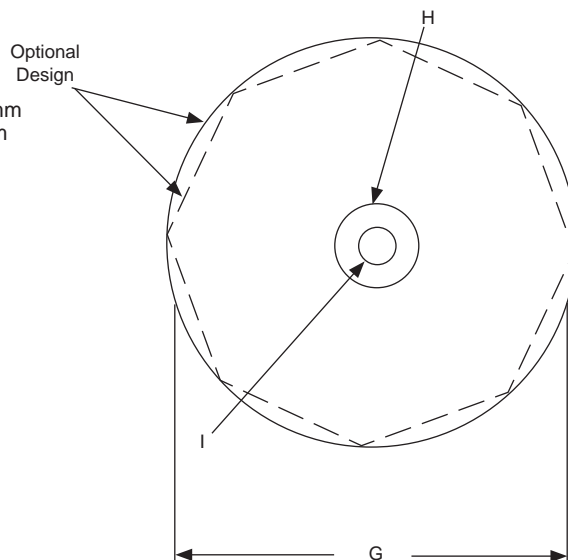

REEL QUANTITIES

NCMA 10	7500 pcs
NCMA 11	5000 pcs
NCMA 20	5000 pcs
NCMA 30	5000 pcs
NCMA 40	5000 pcs

