

FEATURES

- DOUBLE LAYER CONSTRUCTION
- HIGH CURRENT DISCHARGE (UP TO 500 μ A)
- IDEAL FOR LONG TIME BACK-UP POWER SUPPLY
- SUITABLE FOR FLOW SOLDERING
- LEAD-FREE FINISH

RoHS Compliant
includes all homogeneous materials

*See Part Number System for Details



CHARACTERISTICS

Rated Voltage Range	5.5VDC	
Rated Capacitance Range	0.01F ~ 4.7F (10,000 μ F ~ 4,700,000 μ F)	
Operating Temp. Range	-25°C ~ +70°C	
Capacitance Tolerance	+80%/-20% (Z)	
Load Life Test @ 70°C 1,000 hours	Δ Capacitance Change	Less than \pm 30% of initial measured value
	Maximum ESR	Less than 200% of the specified maximum value
	Current at 30 minutes	Less than 200% of the specified maximum value
Temperature Cycling (5 cycles, -25 ~ +70°C)	Δ Capacitance Change	Within +80%/-20% of specified value
	Maximum ESR	Less than specified maximum value
	Current at 30 minutes	Less than specified maximum value
Humidity Resistance (240 hours @ 40°C/90% RH)	Δ Capacitance Change	Less than \pm 20% of initial measured value
	Maximum ESR	Less than 120% of the specified maximum value
	Current at 30 minutes	Less than 120% of the specified maximum value

Super Capacitor
Application Guide

STANDARD VALUES AND SPECIFICATIONS

NIC P/N	Capacitance Value (F)		Holding Voltage (VDC min.)	Max. Current @ 30 minutes (mA)	Max. ESR @ 1KHz (Ω)	Typical DCR (Ω)
	Charge	Discharge				
NEXG103Z5.5V11X5.5F	0.01	0.013	4.2	0.015	300	94
NEXG223Z5.5V11X5.5F	0.022	0.028	4.2	0.033	200	31
NEXG473Z5.5V11X5.5F	0.047	0.060	4.2	0.071	200	29
NEXG104Z5.5V11X6.5F	0.10	0.13	4.2	0.15	100	16
NEXG224Z5.5V13X9F	0.22	0.28	4.2	0.33	100	15
NEXG474Z5.5V14.5X18F	0.47	0.60	4.2	0.71	120	26
NEXG105Z5.5V16.5X19F	1.0	1.3	4.2	1.5	65	14
NEXG225Z5.5V21.5X19F	2.2	2.8	4.2	3.3	35	7
NEXG475Z5.5V28.5X22F	4.7	6.0	4.2	7.1	35	3.2

CASE DIMENSIONS (mm)

NIC P/N	DIMENSIONS (mm)					
	D	H	S	LL	d1	d2
NEXG103Z5.5V11X5.5F	11.0	5.5	5.08	2.7	0.2	1.2
NEXG223Z5.5V11X5.5F	11.0	5.5	5.08	2.7	0.2	1.2
NEXG473Z5.5V11X5.5F	11.0	5.5	5.08	2.7	0.2	1.2
NEXG104Z5.5V11X6.5F	11.0	6.5	5.08	2.7	0.2	1.2
NEXG224Z5.5V13X9F	13.0	9.0	5.08	2.2	0.4	1.2
NEXG474Z5.5V14.5X18F	14.5	18.0	5.08	2.4	0.4	1.2
NEXG105Z5.5V16.5X19F	16.5	19.0	5.08	2.7	0.4	1.2
NEXG225Z5.5V21.5X19F	21.5	19.0	7.62	3.0	0.6	1.2
NEXG475Z5.5V28.5X22F	28.5	22.0	10.16	6.1	0.6	1.4

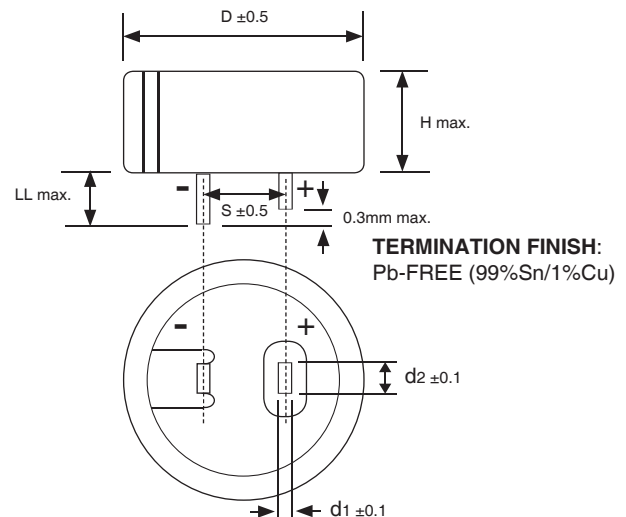

PRECAUTIONS

WASHING is NOT RECOMMENDED. Additional guidelines and precautions can be found at www.niccomp.com/precautions
If in doubt or uncertainty, please review your specific application - process details with NIC's technical support personnel: tpmg@niccomp.com

