

FEATURES

- X7R, X5R AND Y5V DIELECTRICS
- HIGH CAPACITANCE DENSITY
- ULTRA LOW ESR & ESL
- EXCELLENT MECHANICAL STRENGTH
- NICKEL BARRIER TERMINATIONS
- RoHS COMPLIANT
- SAC SOLDER COMPATIBLE*

RoHS Compliant

Includes all homogeneous materials

*See Part Number System for Details

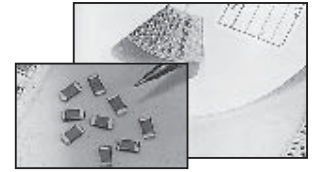

Temperature Coefficient	X7R	X5R	Y5V
Capacitance Range	1.0 μ F ~ 10 μ F	1.0 μ F ~ 100 μ F	1.0 μ F ~ 100 μ F
Capacitance Tolerance	10% (K) & 20% (M)	10% (K) & 20% (M)	+80%/-20% (Z)
Operating Temperature Range	-55°C ~ +125°C	-55°C ~ +85°C	-30°C ~ +85°C
Temperature Characteristics	$\pm 15\%$ Δ Cap.	$\pm 15\%$ Δ Cap.	+22%, -82% Δ Cap.
Rated Voltages	4Vdc, 6.3Vdc, 16Vdc, 25Vdc, 50Vdc & 100Vdc		
Dissipation Factor	See Sizes & Values Tables		
Insulation Resistance	100Megohm/ μ F minimum @ +25°C		
Dielectric Withstanding Voltage	250% of Rated Voltage for 5 \pm 1 sec., 50mA max.		150% of Rated Voltage for 5 \pm 1 sec., 50mA max.
Test Conditions (EIA-198-2E)	C \leq 10 μ F 1KHz, 1.0V \pm 0.2Vrms (ALC on) C > 10 μ F 120Hz, 0.5V \pm 0.2Vrms (ALC on)		1KHz, 1.0V \pm 0.1Vrms (ALC on)

*Reflow soldering is recommended. Contact NIC regarding the use of other soldering methods.

PART NUMBER SYSTEM

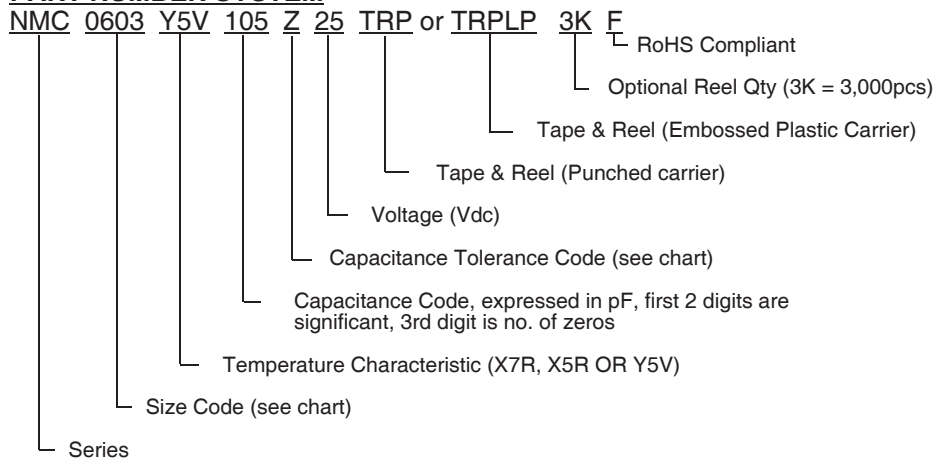

Typical ESR versus Frequency

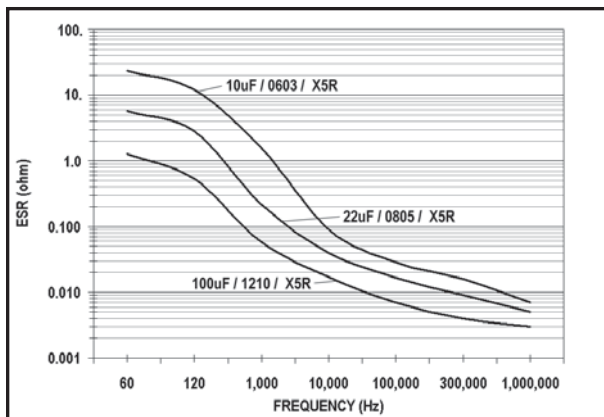

Typical Capacitance versus Bias Voltage

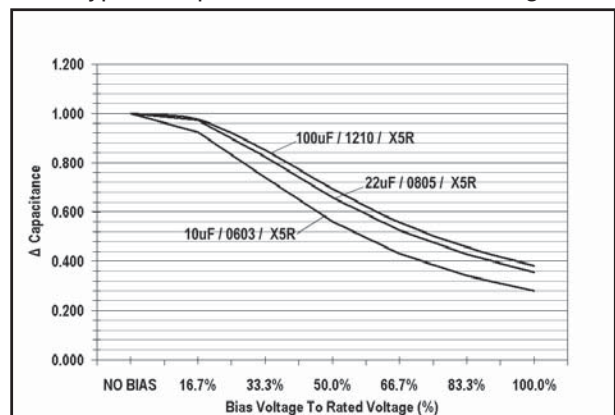

X7R HIGH CV CAPACITOR VALUES AND SIZES (mm)

EIA Case Size	0603				0805				1206				
Length (L)	1.6 ± 0.15				2.0 ± 0.2				3.2±0.2				
Width (W)	0.8 ± 0.15				1.25 ± 0.2				1.6±0.2				
Thickness max. (T)	1.0				1.35				1.90				
Termination Width (P)	0.1 ~ 0.65				0.25 ~ 0.75				0.25 ~ 0.85				
Capacitance	Working Voltage (Vdc)												
	6.3V	10	16	6.3	10	16	25	6.3	10	16	25	35	50
1.0µF		5%	5%		5%	3.5%	5%		5%	5%	3.5%		3%
1.5µF													
2.2µF	10%			10%*	5%*	5%*	5%*		5%	5%	3.5%		
3.3µF				10%*					5%	5%	3.5%		
4.7µF				10%*					5%	5%	3.5%		
10µF				15%*				10%	5%	3.5%**			

* 1.45mm maximum thickness, **2.20mm maximum thickness

Percentages in the table represent the dissipation factor for that value.

X7R HIGH CV CAPACITOR VALUES AND SIZES (mm)

EIA Case Size	1210						1812				2225			
Length (L)	3.2±0.2						4.5±0.4				5.7±0.4			
Width (W)	2.5±0.2						3.2±0.3				6.35±0.25			
Thickness max. (T)	2.20						1.8				2.20			
Termination Width (P)	0.25 ~ 1.00						0.25 ~ 1.5				0.25 ~ 1.02			
Capacitance	Working Voltage (Vdc)													
	10	16	25	35	50	100	10	16	25	50	100	25	50	100
1.0µF	5%	3.5%	3.5%		3.5%	2.5%**	5%	3.5%	3.5%	2.5%*	2.5%*	2.5%	2.5%	2.5%
1.5µF												2.5%		
2.2µF			3.5%									2.5%		
3.3µF			3.5%											
4.7µF		3.5%	5%	2.5%**										
10µF	5%	3.5%	5%**											

*2.20mm maximum thickness, **2.80mm maximum thickness

Percentages in the table represent the dissipation factor for that value.

(CONSULT FACTORY
FOR CAPACITANCE
VALUES NOT LISTED)

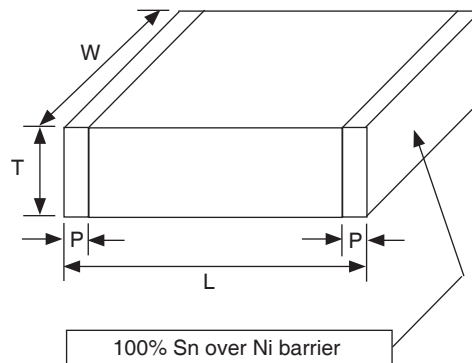

X5R HIGH CV CAPACITOR VALUES AND SIZES (mm)

EIA Case Size	0402				0603					0805					
Length (L)	1.0 ± 0.05				1.6 ± 0.15					2.0 ± 0.2					
Width (W)	0.5 ± 0.05				0.8 ± 0.15					1.25 ± 0.2					
Thickness max. (T)	0.6				1.0					1.45					
Termination Width (P)	0.1 ~ 0.3				0.1 ~ 0.65					0.20 ~ 0.75					
Capacitance	Working Voltage (Vdc)														
	4	6.3	10	16	4	6.3	10	16	25	4	6.3	10	16	25	
1.0µF		10%	15%	10%		10%	10%	5%	5%		10%	7.5%	5%	5%	
1.5µF						10%	10%	3.5%			10%	10%	5%	5%	
2.2µF	10%	10%				10%	10%				10%	10%			
3.3µF						10%					10%	10%			
4.7µF	10%	12.5%*				10%	5%				10%	10%	10%	10%	
6.8µF															
10µF					10%	10%					10%	10%	10%		
22µF					12.5%						15%				
47µF									10%						

*T max. 0.65mm, L & W tolerance -0/+0.15mm

Percentages in the table represent the dissipation factor for that value.

X5R HIGH CV CAPACITOR VALUES AND SIZES (mm)

EIA Case Size	1206					1210				
Length (L)	3.2±0.2					3.2±0.3				
Width (W)	1.6±0.2					2.5±0.2				
Thickness max. (T)	1.90					2.2				
Termination Width (P)	0.25 ~ 0.85					0.25 ~ 1.0				
Capacitance	Working Voltage (Vdc)									
	4	6.3	10	16	25	6.3	10	16	25	35
1.0µF										
1.5µF				5%						
2.2µF		10%	7.5%	5%	3.5%					3.5%
3.3µF		10%	7.5%	5%	3.5%					
4.7µF		10%	7.5%	5%	5%	10%	5%	3.5%	3.5%*	
6.8µF		10%								
10µF		10%	10%	5%	5%	10%	5%	5%	5%*	10%
22µF		10%	10%	3.5%		10%*	10%*	5%*	2.5%*	
47µF	10%	10%	10%			10%*	10%*			
100µF						15%*				

*Length 3.2mm ± 0.4mm, 2.8mm maximum thickness

(CONSULT FACTORY FOR CAPACITANCE VALUES NOT LISTED)

Percentages in the table represent the dissipation factor for that value.

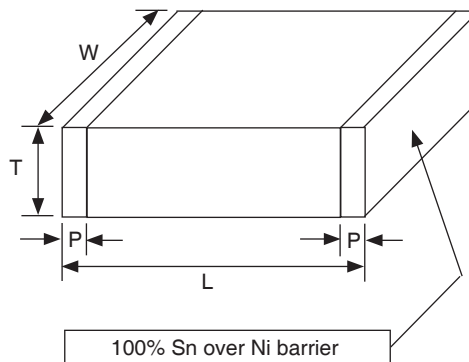

Y5V HIGH CV CAPACITOR VALUES AND SIZES (mm)

EIA Case Size	0402		0603				0805				
Length (L)	1.0 ± 0.05		1.6 ± 0.15				2.0 ± 0.2				
Width (W)	0.5 ± 0.05		0.8 ± 0.15				1.25 ± 0.2				
Thickness max. (T)	0.6		1.0				1.45				
Termination Width (P)	0.1 ~ 0.3		0.1 ~ 0.65				0.25 ~ 0.75				
Capacitance	Working Voltage (Vdc)										
	6.3	10	6.3	10	16	25	6.3	10	16	25	50
1.0µF	20%	12.5%		16%	16%	9%	16%	12.5%	9%	9%	9%
1.5µF							16%	12.5%	9%		
2.2µF			20%	16%	16%		16%	12.5%	9%	9%	
3.3µF							16%	12.5%	9%		
4.7µF			20%	12.5%			16%	12.5%	12.5%		
6.8µF								16%			
10µF							20%	30%			
22µF							20%				

*2.5mm maximum thickness

Percentages in the table represent the dissipation factor for that value.

Y5V HIGH CV CAPACITOR VALUES AND SIZES (mm)

EIA Case Size	1206						1210					1812					
Length (L)	3.2±0.2						3.2±0.2					4.5±0.4					
Width (W)	1.6±0.2						2.5±0.2					3.2±0.3					
Thickness max. (T)	1.90						2.2					2.8					
Termination Width (P)	0.25 ~ 0.85						0.25 ~ 1.0					0.25 ~ 1.5					
Capacitance	Working Voltage (Vdc)																
	6.3	10	16	25	35	50	6.3	10	16	25	35	50	6.3	10	16	25	50
1.0µF		12.5%	12.5%	7%		7%		12.5%	12.5%	9%		7%		12.5%	9%	5%	5%
1.5µF		12.5%	12.5%	9%				12.5%	12.5%	9%				12.5%	9%	5%	5%
2.2µF		12.5%	12.5%	9%		9%		12.5%	12.5%	9%		7%		12.5%	9%	5%	5%
3.3µF		12.5%	12.5%	9%				12.5%	12.5%	9%				12.5%	9%	5%	5%
4.7µF		12.5%	12.5%	9%	7%		20%	12.5%	12.5%	9%		7%		12.5%	9%	5%	5%
6.8µF		16%	12.5%					12.5%	12.5%	9%				12.5%	9%	5%	5%
10µF	20%	16%	12.5%	9%	9%			16%	12.5%	9%	7%			12.5%	9%	5%	5%
22µF	20%	16%					20%	16%	16%								5%
33µF																	
47µF							20%	16%						16%	9%		
100µF							20%*						20%	16%			

*2.8mm maximum thickness

Percentages in the table represent the dissipation factor for that value.

(CONSULT FACTORY FOR CAPACITANCE VALUES NOT LISTED)

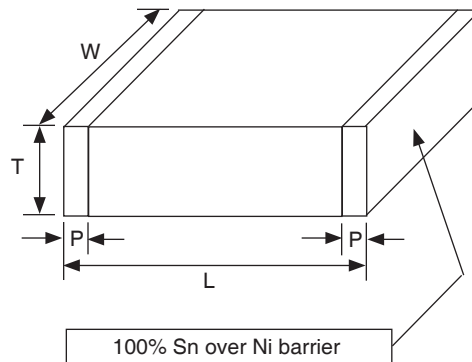

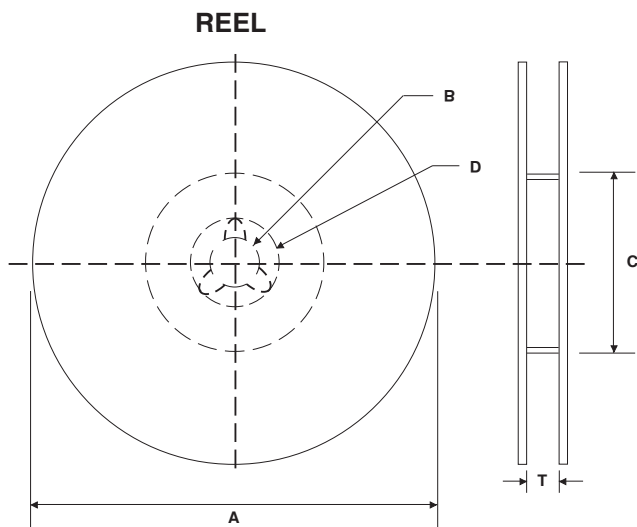

REEL DIMENSIONS (mm)

Reel Diameter (A)	B	C	D	T max.
7" (178 ± 2.0)	13 ± 0.5	50 min.	21 ± 1.0	8.4 +1.0/-0 (1812 case size 12.4 +2.0/-0)
10" (250 ± 2.0)		100 ± 1.0		
13" (330 ± 2.0)		100 ± 1.0		

7 INCH REEL QUANTITIES*

Size	01005	0201	0402	0603	0805	1206	1210	1812
Tape Size	8mm	8mm	8mm	8mm	8mm	8mm	8mm	12mm
Min. Qty Per Reel	20,000	20,000	10,000	4,000	4,000	4,000	2,000	1,000
Max. Qty Per Reel	20,000	20,000	10,000	4,000	5,000	5,000	5,000	2,000

*Quantity dependent on chip thickness. Contact NIC for reel quantities on larger diameter reels.

CARRIER TAPE MATERIAL

Parts with a thickness of ≥1mm will be taped on embossed plastic carrier. Parts with a thickness of less than 1mm will be taped on paper carrier

EMBOSSED PLASTIC CARRIER TAPE DIMENSIONS (mm)

Tape Size	W	F	E	P ₀	P ₂	D	K max.	T max.	P
8mm	8.0 ± 0.2	3.5 ± 0.05	1.75 ± 0.10	4.0 ± 0.1	2.0 ± 0.5	1.5 ^{+0.1} _{-0.0}	0.3	2.0	4.0 ± 0.1
12mm	12 ± 0.2	5.5 ± 0.05						4.5	8.0 ± 0.1

Notes:

- Specifications are in compliance with EIA RS481-1-A "Taping of surface Mount Components for Automatic Placement"
- Dimensions A₀ (max.) equals component width dimension plus 0.5mm
- Dimension B₀ (max.) equals component length dimension plus 0.5mm

EMBOSSED PLASTIC CARRIER TAPE

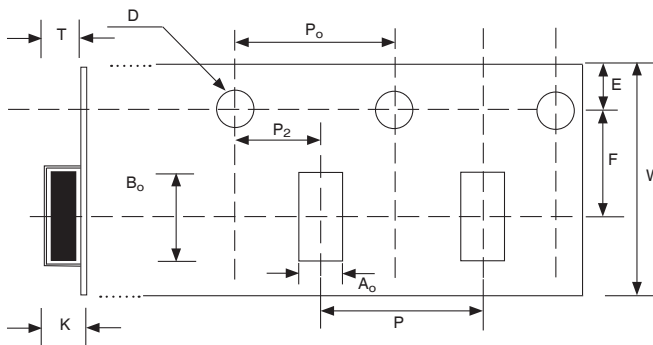

See notes 2 & 3 regarding dimensions A₀ and B₀

PUNCHED CARRIER TAPE DIMENSIONS (mm)

Type	A ₀	B ₀	W	F	E	P1	P0	D0	T1 max.	T2 max.	Mounting Hole	
01005	0.25 ± 0.04	0.45 ± 0.04	8.0 ± 0.3	3.5 ± 0.05	1.75 ± 0.1	2.0 ± 0.05	4.0 ± 0.1	1.5 ^{+0.1/-0.0}	0.27	0.36	Angular Punch Hole	
0201	0.37 ± 0.03	0.67 ± 0.05							4.0 ± 0.10	0.45		0.80
0402	0.65 ± 0.05	1.15 ± 0.05								1.1		1.4
0603	1.1 ± 0.2	1.9 ± 0.2				4.0 ± 0.10			1.1	1.4		
0805	1.65 ± 0.2	2.4 ± 0.2										
1206	2.0 ± 0.2	3.6 ± 0.2										

PUNCHED CARRIER TAPE

