

# ST1 Series

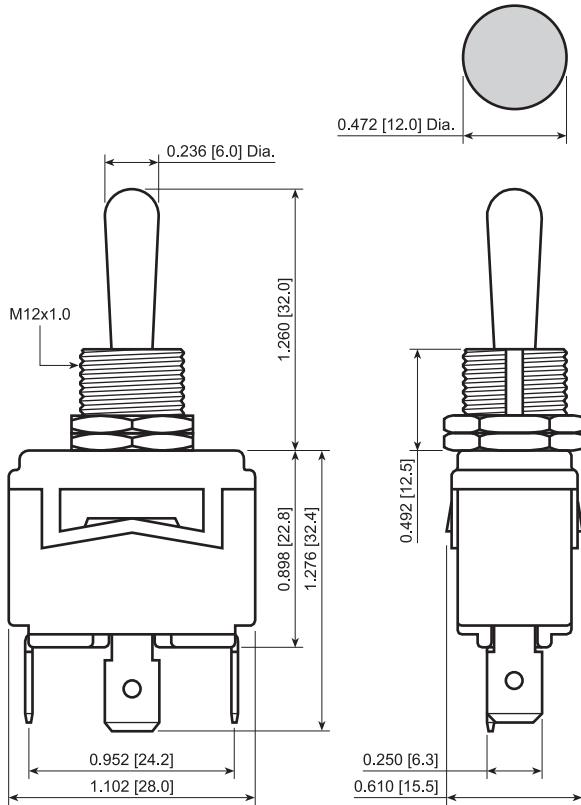

## Panel Cutout



## Actuator Options

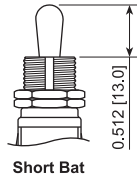

## Bushing Options

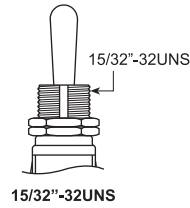

## Terminal Options

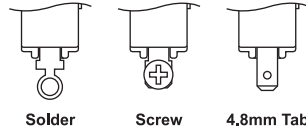

## Water Protection Options



## FEATURES:

- Heavy Duty Rating with UL Approvals
- Many Functions Available
- Tab, Screw, and Solder Terminal Options
- Rubber Boot for Water and Dust Protection

## SPECIFICATIONS:

### RATING: MAINTAINED SWITCHES:

- 20A 125VAC [cULus]
- 15A 250VAC [cULus]
- 2HP 125-250VAC [cULus]

### MOMENTARY SWITCHES:

- 20A 125VAC [cULus]
- 15A 250VAC [cULus]
- 1.5HP 125-250VAC [cULus]

### TEMPERATURE: -20°C to 85°C

### ELECTRICAL LIFE: 6,000 Cycles

### CONTACT RESISTANCE: 50mΩ Max.

### INSULATION RESISTANCE: 800MΩ Min. at 500VDC

### DIELECTRIC STRENGTH: 1,500VAC for 1 Minute

## MATERIALS:

- BODY:** Phenolic, UL94 V-0
- ACTUATOR:** Nickel Plated Brass
- BUSHING:** Nickel Plated Brass
- HOUSING:** Stainless Steel
- CONTACTS:** Silver Alloy
- TERMINALS:** Silver Plated Brass

Series	Terminal	Function	Rating	Actuator Type	Bushing Type
ST1 - 1 Pole	1 - 4.8mm Tabs 2 - Solder 4 - 6.3mm Tabs 6 - Screw	1 Pole: 1 - Off-On 3 - On-On 4 - Off-(On), Middle-End 5 - On-Off-On C - On-Off-(On) D - (On)-Off-(On)	D - 20A 125VAC	0 - Standard Bat 1 - Short Bat	0 - M12x1.0 2 - 15/32"-32UNS

Variable Length:  
Wxx - Wire Leads  
(xx in Inches)



ST161D10



Accessories Series	Type	Options
ACC	Rubber Boot: B03 - For Standard Bat	Colors for Boot: 2 - Black
	Marking Plates: M01 - ON/OFF	Colors for Marking Plates: 3 - Black, Red, and Silver
	Hardware: N02 - Knurled Nut	Threading: 3 - 15/32"-32UNS 5 - M12x1.0

## EXAMPLE PART NUMBERS:

ST121D00	1P Off-On Standard Actuator/Bushing, Solder
ST123D00	1P On-On Standard Actuator/Bushing, Solder
ST124D00	1P Off-(On) Standard Actuator/Bushing, Solder
ST125D00	1P On-Off-On Standard Actuator/Bushing, Solder
ST12DD00	1P (On)-Off-(On) Standard Actuator/Bushing, Solder
ST141D00	1P Off-On Standard Actuator/Bushing, 0.250" QC
ST143D00	1P On-On Standard Actuator/Bushing, 0.250" QC
ST144D00	1P Off-(On) Standard Actuator/Bushing, 0.250" QC

