

FEATURES

- SHIELDED POWER INDUCTOR
- AUTOMATIC ASSEMBLY
- ROBUST CONSTRUCTION
- HIGH EFFICIENCY
- HIGH CURRENT RATINGS
- ULTRA LOW PROFILE (1.0 ~ 1.2mm HEIGHTS)
- SURFACE MOUNTABLE CONSTRUCTION
- TAPED AND REELED FOR AUTOMATIC INSERTION

**RoHS
Compliant**
includes all homogeneous materials

*See Part Number System for Details

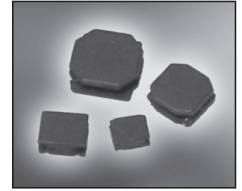

CHARACTERISTICS

Case Size	NPIM26LP	NPIM20LP	NPIM21LP
Inductance Range	0.24 ~ 4.7μH	0.24 ~ 4.7μH	0.24 ~ 10μH
Ambient Operating Temperature Range	-55°C ~ +125°C (including self-heating)		
Temperature Rise at Irms	Maximum +40°C Temperature Rise		
Inductance Change at Isat	Maximum -30% Inductance Drop From Initial Measured Value		
Inductance Tolerance	±20% (M)		
Resistance to Solder Heat	+260°C for 10 seconds		

DIMENSIONS (mm)

Series	Component Dimensions					Land Pattern Dimensions		
	A	B	C	D	E	F	G	H
NPIM26LP	2.0 -0.1/+0.2	1.6 -0.1/+0.2	1.0 max.	0.50 ref.	1.0 ref.	0.8	2.3	1.9
NPIM20LP	2.5 -0.1/+0.2	2.0 -0.1/+0.2	1.0 max.	0.75 ref.	1.0 ref.	1.0	2.9	2.4
NPIM21LP	2.5 -0.1/+0.2	2.0 -0.1/+0.2	1.2 max.	0.75 ref.	1.0 ref.	1.0	2.9	2.4

NPIM26LP & NPIM20LP

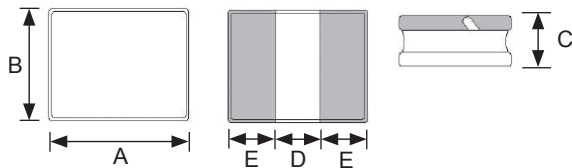

NPIM21LP

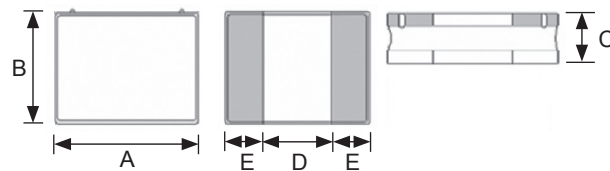

REFLOW SOLDERING
LAND PATTERN (All Sizes)

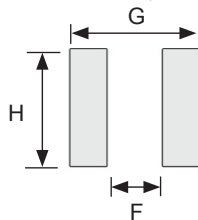

PART NUMBER SYSTEM

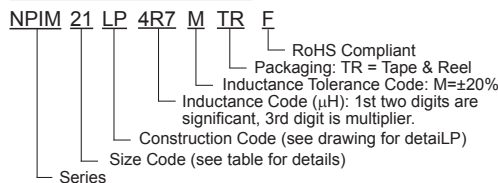

NPIM26LP Size

Series	Standard Values - Case Size 26 (2.0×1.6×1.0mm)							
	Inductance (μH)	Test Conditions	DCR (Ω)		Isat* (Amps)		IDC* (Amps)	
			Typ.	Max.	Typ.	Max.	Typ.	Max.
NPIM26LPR24MTRF	0.24 ± 20%	1MHz, 1V	0.015	0.020	7.5	6.5	6.50	5.50
NPIM26LPR33MTRF	0.33 ± 20%		0.018	0.023	5.5	5.0	5.60	5.20
NPIM26LPR47MTRF	0.47 ± 20%		0.024	0.029	5.2	4.5	5.30	4.70
NPIM26LPR68MTRF	0.68 ± 20%		0.036	0.044	5.1	4.4	4.20	3.80
NPIM26LP1R0MTRF	1.0 ± 20%		0.050	0.060	4.5	4.0	3.40	3.10
NPIM26LP1R5MTRF	1.5 ± 20%		0.068	0.082	3.2	2.8	3.10	2.70
NPIM26LP2R2MTRF	2.2 ± 20%		0.10	0.120	2.7	2.4	2.30	2.10
NPIM26LP3R3MTRF	3.3 ± 20%		0.16	0.192	2.0	1.7	2.00	1.80
NPIM26LP4R7MTRF	4.7 ± 20%		0.18	0.216	1.6	1.4	1.80	1.60

*Maximum +40°C temperature rise at IDC. Maximum -30% inductance drop from initial measured value at Isat. See page 5 for Isat/Irms Test Conditions.

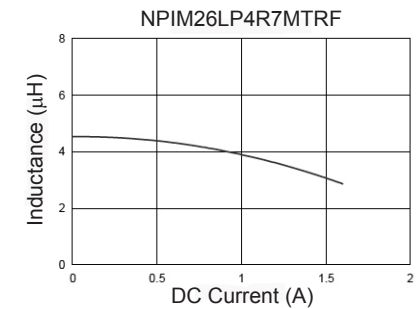
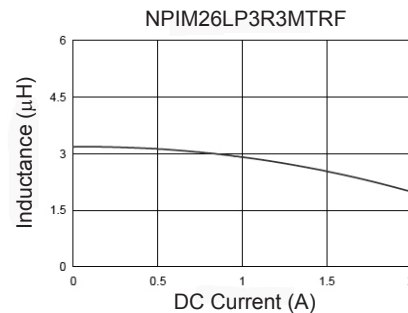
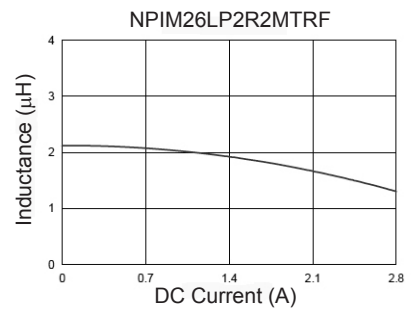
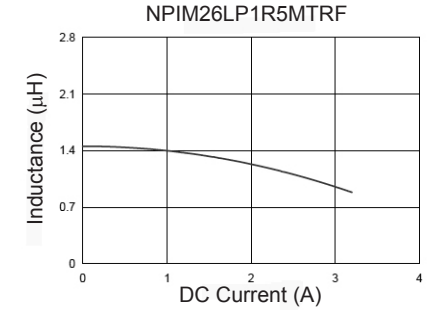
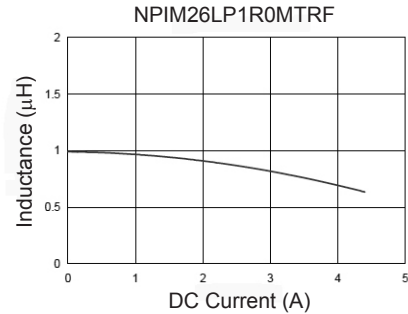
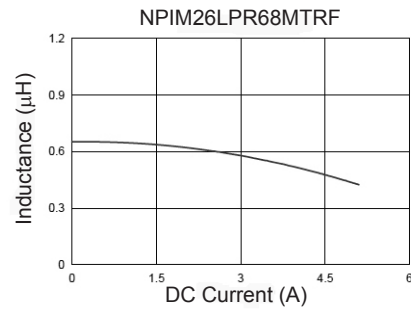
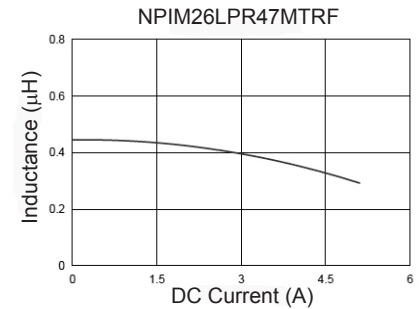
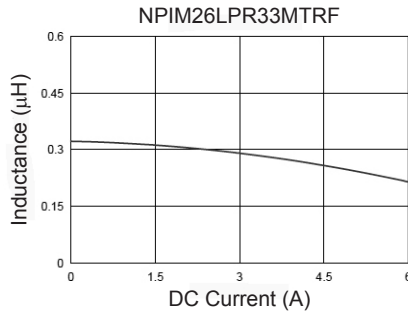
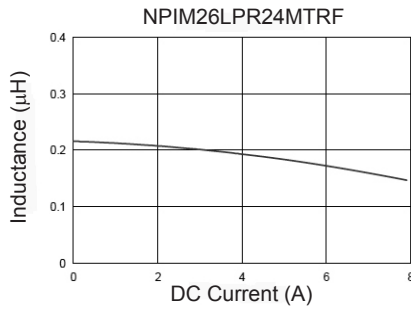

NPIM20LP Size

Series	Standard Values - Case Size 20 (2.5×2.0×1.0mm)							
	Inductance (μH)	Test Conditions	DCR (Ω)		Isat* (Amps)		IDC* (Amps)	
			Typ.	Max.	Typ.	Max.	Typ.	Max.
NPIM20LPR24MTRF	0.24 ± 20%	1MHz, 1V	0.018	0.022	9.5	8.0	6.00	5.50
NPIM20LPR33MTRF	0.33 ± 20%		0.023	0.028	8.0	6.5	5.60	5.10
NPIM20LPR47MTRF	0.47 ± 20%		0.027	0.035	7.0	5.9	5.30	4.80
NPIM20LPR68MTRF	0.68 ± 20%		0.032	0.040	5.5	4.6	4.40	4.00
NPIM20LP1R0MTRF	1.0 ± 20%		0.044	0.053	4.9	4.3	3.70	3.40
NPIM20LP1R5MTRF	1.5 ± 20%		0.062	0.074	3.8	3.1	3.40	3.00
NPIM20LP2R2MTRF	2.2 ± 20%		0.078	0.093	2.8	2.3	2.80	2.50
NPIM20LP3R3MTRF	3.3 ± 20%		0.125	0.150	2.1	1.8	2.20	2.00
NPIM20LP4R7MTRF	4.7 ± 20%		0.180	0.216	1.7	1.4	1.80	1.60

*Maximum +40°C temperature rise at IDC. Maximum -30% inductance drop from initial measured value at Isat. See page 5 for Isat/Irms Test Conditions.

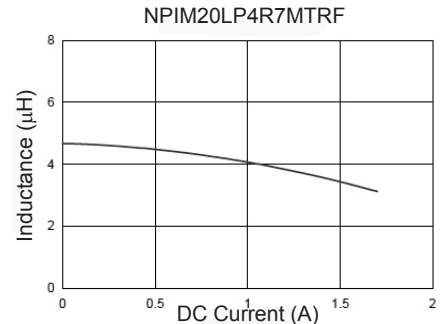
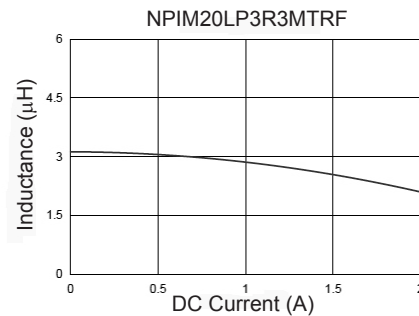
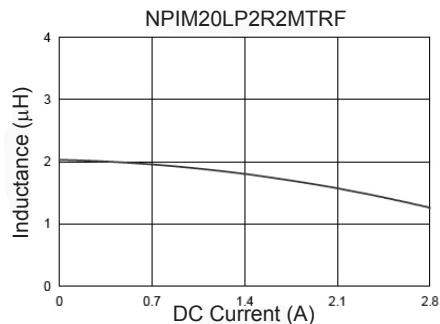
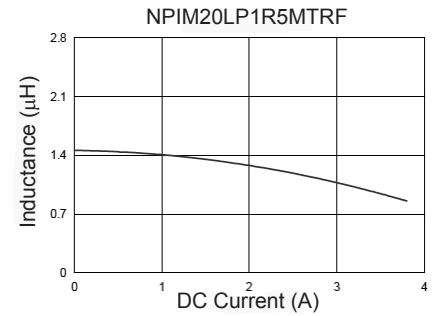
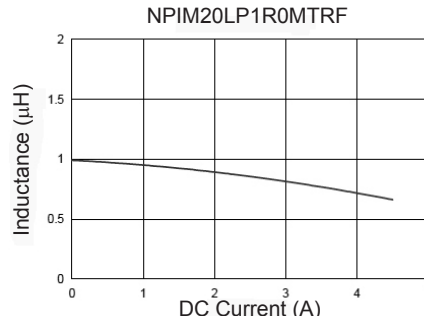
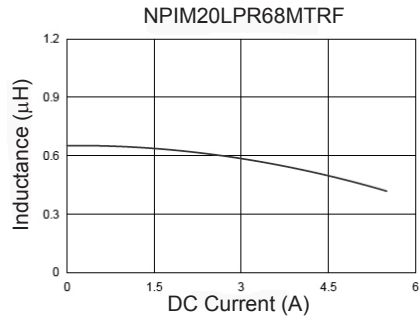
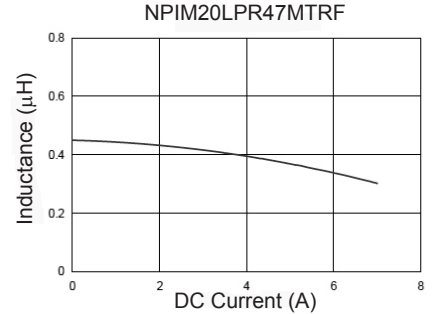
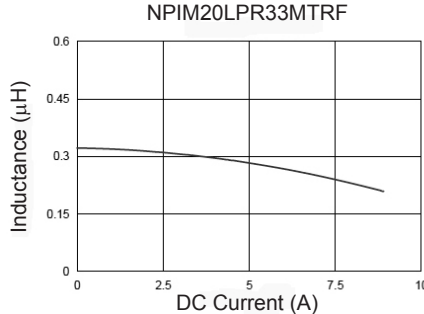
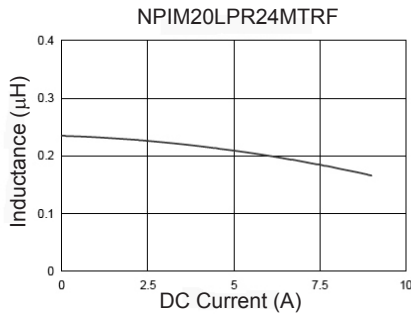

NPIM21LP Size

Series	Standard Values - Case Size 21 (2.5×2.0×1.2mm)							
	Inductance (μH)	Test Conditions	DCR (Ω)		Isat* (Amps)		IDC* (Amps)	
			Typ.	Max.	Typ.	Max.	Typ.	Max.
NPIM21LPR24MTRF	0.24 ± 20%	1MHz, 1V	0.018	0.022	8.0	7.0	6.00	5.50
NPIM21LPR33MTRF	0.33 ± 20%		0.023	0.028	7.0	6.0	5.60	5.10
NPIM21LPR47MTRF	0.47 ± 20%		0.027	0.035	6.0	5.0	5.30	4.80
NPIM21LPR68MTRF	0.68 ± 20%		0.036	0.045	5.0	4.5	4.50	4.00
NPIM21LP1R0MTRF	1.0 ± 20%		0.045	0.058	4.3	3.8	3.80	3.50
NPIM21LP1R5MTRF	1.5 ± 20%		0.060	0.072	3.5	3.0	3.50	3.10
NPIM21LP2R2MTRF	2.2 ± 20%		0.090	0.108	3.1	2.6	2.80	2.50
NPIM21LP3R3MTRF	3.3 ± 20%		0.125	0.150	2.2	1.9	2.50	2.20
NPIM21LP4R7MTRF	4.7 ± 20%		0.190	0.220	2.0	1.7	1.90	1.60
NPIM21LP6R8MTRF	6.8 ± 20%		0.300	0.360	1.8	1.5	1.30	1.10
NPIM21LP100MTRF	10 ± 20%		0.420	0.475	1.4	1.1	1.10	1.00

*Maximum +40°C temperature rise at IDC. Maximum -30% inductance drop from initial measured value at Isat. See page 5 for Isat/Irms Test Conditions.

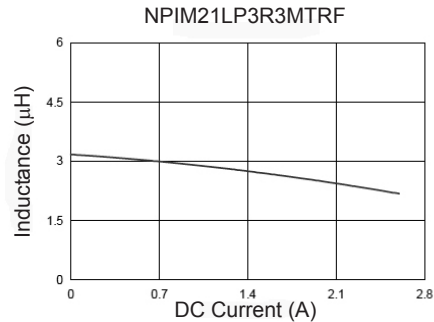
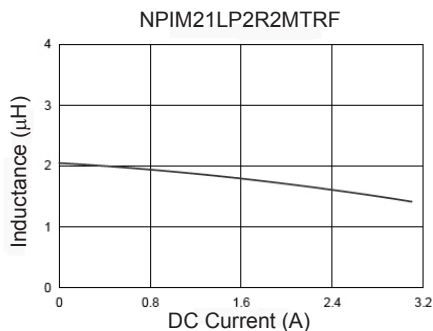
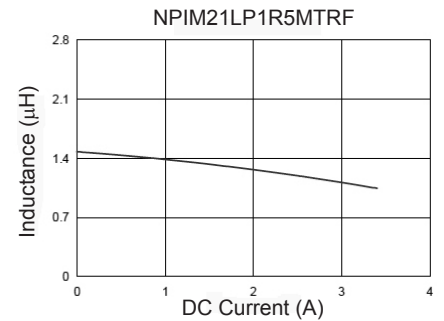
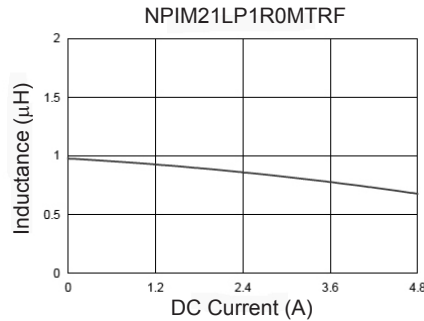
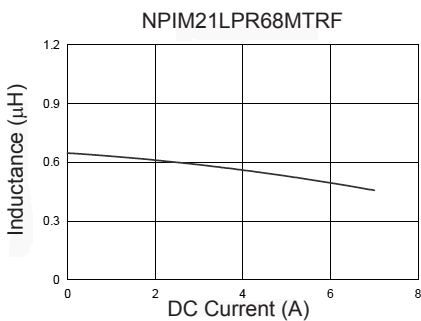
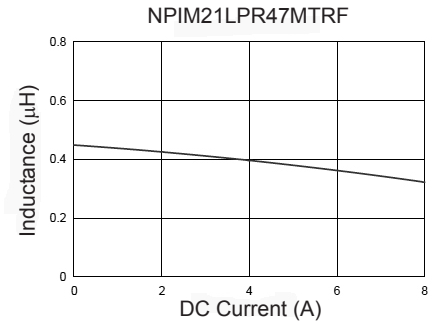
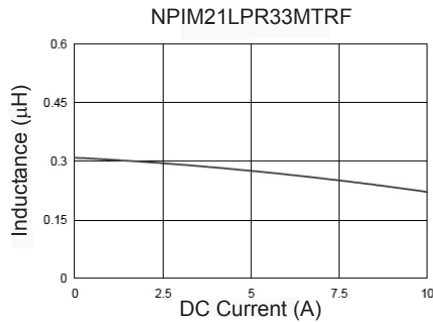
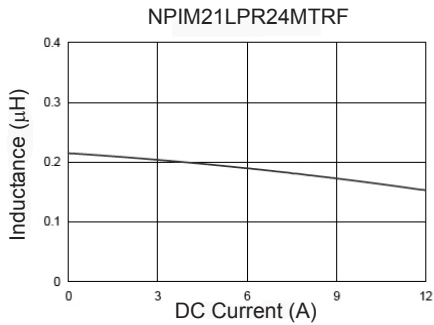

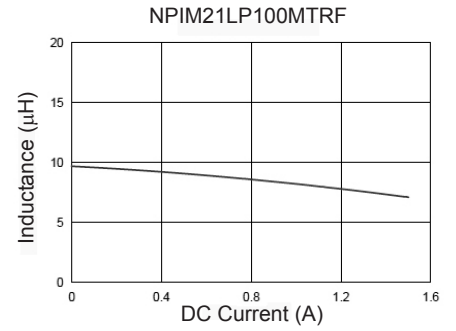
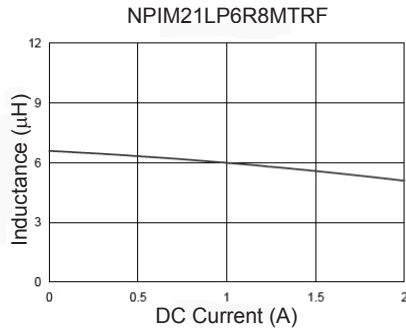
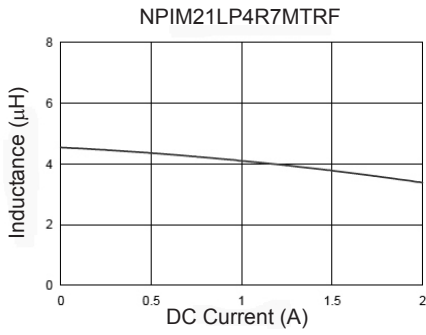

Irms Test Conditions (Board Measurement Data)

Material: FR4
 Board dimensions : 100 X 50 X 1.6t mm
 Pattern dimensions: 45 X 45 mm (Double side board)
 Pattern thickness : 70 µm

Case Size	CARRIER TAPING DIMENSIONS (mm) AND REEL QUANTITY						
	Ao	Bo	Ko	W	Po	t	Quantity
NPIM26LP	2.00 ± 0.1	2.50 ± 0.1	1.4 ± 0.1	8.0 ± 0.1	4.0 ± 0.1	0.23 ± 0.05	2,000
NPIM20LP	2.45 ± 0.1	2.85 ± 0.1	1.4 ± 0.1	8.0 ± 0.1	4.0 ± 0.1	0.23 ± 0.05	2,000
NPIM21LP							

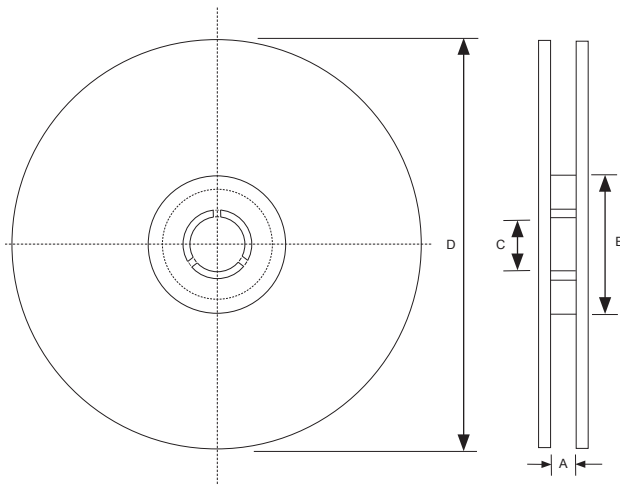
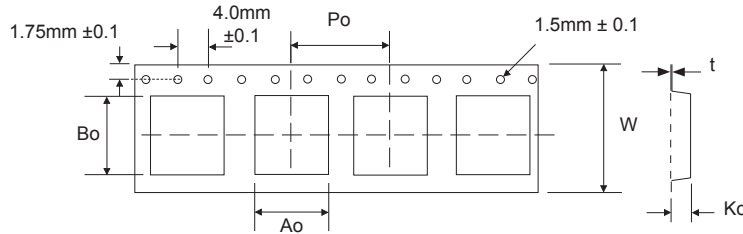

Tape Width	REEL DIMENSIONS (mm)			
	A(mm)	B(mm)	C(mm)	D(mm)
NPIM26LP	8.4 ± 1.0	50 min.	13.0 ± 0.8	178 ± 2.0
NPIM20LP				
NPIM21LP				

REFLOW SOLDERING PROFILE

